

Identification of Novel Gene Variants in Turkish Families with Non-Syndromic Congenital Cataracts Using Whole-Exome Sequencing

Ayberk Türkyılmaz (✉ ayberkturkyilmaz@gmail.com)

Karadeniz Technical University Faculty of Medicine: Karadeniz Teknik Üniversitesi Tıp Fakültesi <https://orcid.org/0000-0001-9647-8970>

Aysin Tuba Kaplan

Istanbul Dr Lufti Kırdar Kartal Eğitim ve Araştırma Hastanesi

Sibel Öskan Yalçın

Istanbul Dr Lufti Kırdar Kartal Eğitim ve Araştırma Hastanesi

Safiye Güneş Sağır

Istanbul Dr Lufti Kırdar Kartal Eğitim ve Araştırma Hastanesi

Şaban Şimşek

Istanbul Dr Lufti Kırdar Kartal Eğitim ve Araştırma Hastanesi

Research Article

Keywords: Congenital cataract, DNMBP gene, Molecular genetics, Whole-exome sequencing

Posted Date: December 2nd, 2021

DOI: <https://doi.org/10.21203/rs.3.rs-1072160/v1>

License: © ⓘ This work is licensed under a Creative Commons Attribution 4.0 International License. [Read Full License](#)

Version of Record: A version of this preprint was published at International Ophthalmology on August 17th, 2023. See the published version at <https://doi.org/10.1007/s10792-023-02857-1>.

Abstract

Purpose The present study aimed to identify the molecular etiology of non-syndromic congenital cataract (CC) using whole-exome sequencing (WES) analysis.

Methods In the present study, ophthalmologic results and pedigree analysis of the families of 12 patients with non-syndromic CC were evaluated. WES analysis was conducted after DNA was isolated from peripheral blood samples obtained from the patients.

Results Twelve non-syndromic probands (10 male and 2 female) with bilateral CC were included in the study. Patient age ranged between 1 and 11 months. WES analysis showed pathogenic/likely pathogenic variant in 7 (58%) of the 12 families and variant of unknown significance (VUS) in 5 (42%) of them. All the 13 different variants detected in 9 different CC-related genes were co-segregated with the disease. Autosomal dominant inheritance was found in 7 (58%) of the families and autosomal recessive inheritance was found in 5 (42%) of them.

Conclusion To the best of our knowledge, the present research is one of the limited numbers of studies in the Turkish population in which genetically heterogeneous non-syndromic CC was investigated using WES analysis. Novel variants that we identified in *DNMP*, *LSS*, and *WFS1* genes, which are rarely associated with the CC phenotype, have contributed to the mutation spectrum of this disease. Identifying the relevant molecular genetic etiology allows accurate genetic counseling to be provided to the families.

Introduction

Congenital cataract (CC) develops in the first year of life. CC is one of the most common treatable causes of childhood visual impairment (1). The prevalence of CC is 1–15 per 10,000 live births [1]. Various factors play a role in the etiology of CC. These include history of intrauterine infection in the prenatal period, history of hypoxia, metabolic diseases, malnutrition, and hereditary factors [2].

Almost half of all CC cases are caused by hereditary factors. Hereditary CC cases can be categorized under two headings: non-syndromic cases that are isolated wherein only the lens is affected and syndromic cases wherein organs outside the lens are also affected. To date, more than 100 genes associated with CC have been published in the online Mendelian Inheritance in Man (OMIM) and Cat-Map databases (<http://cat-map.wustl.edu/> and www.omim.org). Different inheritance patterns have been identified in inherited CC cases. However, autosomal dominant inheritance is the most common among these patterns. CC presents as a syndrome feature in different syndromes. Furthermore, isolated CC has been observed in some cases in which variant was detected in syndromic CC-related genes (e.g., *AGK*, *WFS1*, and *EYAT1*). In addition, same variation in the same gene can lead to different cataract types. This leads to the observation of clinical and genetic heterogeneity in CC cases [3].

Non-syndromic CC develops as a result of variations in the genes encoding crystalline proteins, channel proteins, transcription factors, and cytoskeletal proteins found in the lens. Variations associated with non-syndromic CC have been reported most commonly in the genes encoding crystallin proteins, and these variations usually show autosomal dominant inheritance [4].

The present study aimed to identify the molecular etiology of non-syndromic CC using WES analysis.

Materials And Methods

Patients

A total of 12 index cases (10 male and 2 female) diagnosed with CC and admitted to Kartal Dr. Lütfi Kırdar City Hospital's Ophthalmology Clinic between April 2021 and October 2021, and the first and second degree relatives of these cases having similar phenotypes (10 cases: 4 male and 6 female) were included in this research. All cases included in the study underwent detailed ophthalmologic, neurologic, metabolic examinations and pedigree analysis.

All patients were evaluated by pediatric neurologist and medical geneticist for syndromic features. Only non-syndromic bilateral CC cases were included in the present study. Exclusion criteria included juvenile onset cataract, unilateral cataract, syndromic findings, and maternal exposure intrauterine infection during pregnancy, metabolic or additional systemic disease, and the presence of ocular trauma.

Molecular Analysis

Genomic DNA was isolated from the peripheral blood of patients using the QIAamp DNA Blood Mini QIAcube Kit (Qiagen, Hilden, Germany) as per the manufacturer's protocols. For WES analysis, the libraries were prepared using the QIAseq® Human Exome Kit as per the manufacturer's instructions (Qiagen, Hilden, Germany). Paired-end sequencing (150 bp) was performed on the NovaSeq6000 system according to the manufacturer's guidelines (Illumina Inc., San Diego, CA, USA). Sequence readings were aligned to the human reference genome (hg19/GRCh37) using BWA-MEM (version 0.7.17) and converted to BAM files via SAMtools (version 1.3) [5]. To determine the pathogenic variants, we filtered the following: 1) All nonsynonymous, missense, nonsense, frameshift, splice-site, no-stop, no-start, inDels, and in-frame variants in all protein-coding genes, 2) synonymous or intronic variants affecting the consensus splice sites and creating cryptic splice sites 3) variants with minor allele frequency of <1.0% in population studies 1000 Genome (1000G), Genome Aggregation Database (gnomAD) and 4) variants with a variant frequency of 20–100%. After the filtering steps, about 800-1000 rare variants were detected in each patient. All rare variants in all protein-coding genes were examined considering the patient phenotype. To evaluate the pathogenicity of the novel variants, in silico prediction tools (SIFT, PROVEAN, GERP, CADD, PolyPhen2, and MutationTaster), segregation analysis, allele frequencies in population studies (1000 Genomes, Genome Aggregation Database, and Exome Aggregation Consortium), VarSome, and the American College of Medical Genetics and Genomics (ACMG) criteria were

used [6, 7]. Variants identified as pathogenic in ClinVar and/or Human Genome Mutation Database Professional (HGMD® Pro) were considered to explain the phenotype. Candidate variants identified in the index cases were then examined in the parents and siblings who agreed to participate in the research to undergo segregation analysis.

Results

A total of 22 cases (14 males and 8 females) from 12 unrelated families (12 probands and 10 affected relatives) between 1 month and 63 years of age were included in the present study. The age range of the probands was 1 to 11 months. The median age of cases when they were diagnosed with CC was 5 months. When the cases were examined based on the cataract type, it was found that 5 (42%) were lamellar, 2 were nuclear (17%), 2 were total white (17%), 1 was blue dot (8%), 1 was membranous (8%), and 1 was posterior polar (8%) cataract. Cataract phenotype of some patients were presented in Figure 1. Table 1 shows clinical results of the cases, and Figure 2 shows the pedigree analysis results.

Table 1
Clinical features of congenital cataract families.

Family Number	Patient Number	Cataract type	Age at diagnosis	Age at surgery	Affected gene
F1	II-2	M	6 month	10 month	<i>CRYBB2</i>
F2	I-1	na	28 years	1 year	<i>CRYGA</i>
F2	II-1	BD	3 month	7 month	<i>CRYGA</i>
F3	I-1	na	33 years	1.5 years	<i>CRYBB1</i>
F3	II-1	PP	4 month	9 month	<i>CRYBB1</i>
F4	I-2	na	38 years	1 year	<i>GJA3</i>
F4	II-1	L	5 month	8 month	<i>GJA3</i>
F4	II-2	L	2 month	3 month	<i>GJA3</i>
F5	I-1	na	63 years	1.5 year	<i>GJA3</i>
F5	II-3	na	35 years	na	<i>GJA3</i>
F5	II-4	na	31 years	na	<i>GJA3</i>
F5	III-1	TW	6 month	9 month	<i>GJA3</i>
F6	II-1	L	5 month	11 month	<i>DNMBP</i>
F7	II-1	L	6 month	11 month	<i>DNMBP</i>
F8	I-1	na	32 years	na	<i>WFS1</i>
F8	II-1	L	Birth	6 month	<i>WFS1</i>
F9	I-2	na	28 years	1 year	<i>WFS1</i>
F9	II-1	N	1 month	5 month	<i>WFS1</i>
F10	II-1	TW	6 month	9 month	<i>FYCO1</i>
F11	II-1	L	5 month	10 month	<i>GCNT2</i>
F11	II-2	L	2 month	7 month	<i>GCNT2</i>
F12	II-1	N	3 month	8 month	<i>LSS</i>

F: Family, M: Membranous, N: Nuclear, PP: Posterior polar, L: lamellar, TW: total white, BD: blue dot, na: not available.

Of the index cases included in the study, 12 probands were evaluated by WES analysis. Among these cases, likely pathogenic and pathogenic variants were detected in CC-related genes (*CRYBB2*, *DNMBP*, *FYCO1*, *GJA3*, and *WFS1*) in 7 probands (58%), and variant of unknown significance (VUS) was detected in CC-related genes (*CRYGA*, *CRYBB1*, *DNMBP*, *GCNT2*, and *LSS*) in 5 probands (42%). All of the 13 different variants detected in 9 different CC-related genes were co-segregated with the disease. Autosomal dominant inheritance was found in seven (58%) of the families, of which one had *de novo* variation and the others inherited it from the affected parent, and autosomal recessive inheritance was found in five (42%) of the families. There was a total of 13 variations identified (9 novel variations, 4 previously reported). Of these, 11 (84%) variants were missense, 1 (8%) variant was nonsense, and 1 (8%) variant was an in-frame deletion variant. Of the 12 families included in the present study, variants were identified in genes encoding crystallin and membrane proteins of the lens in 5 (42%) of the families investigated. All variants identified as a result of this study are shown in Table 2.

Table 2
Genetic findings of congenital cataract families.

Family Number	Gene	Transcript	Variant	Variant Type	Zygoty	Inheritance	gnomAD frequency	ACMG Criteria	ClinVar ID/ HGMD ID
Family 1	<i>CRYBB2</i>	NM_000496.3	c.355G>A (p.G119R)	Missense	Het	<i>De novo</i>	Absent	Pathogenic	242473 / CM162360
Family 2	<i>CRYGA</i>	NM_014617.4	c.239G>A (p.R80H)	Missense	Het	Maternal	0.00393	VUS	252950 / CM1712984
Family 3	<i>CRYBB1</i>	NM_001887.4	c.126_128delAAC (p.T43del)	In-frame deletion	Het	Maternal	Absent	VUS	-
Family 4	<i>GJA3</i>	NM_021954.4	c.144_145delGCinsAG (p.Q49E)	Missense	Het	Paternal	Absent	Likely Pathogenic	-
Family 5	<i>GJA3</i>	NM_021954.4	c.65G>A (p.G22D)	Missense	Het	Paternal	Absent	Likely Pathogenic	-
Family 6	<i>DNMBP</i>	NM_015221.4	c.1918C>T (p.R640*)	Nonsense	Hom	Parents: Het	Absent	Pathogenic	-
Family 7	<i>DNMBP</i>	NM_001318326.2	c.395G>A (p.G132E) / c.960G>T (p.Q320H)	Missense	Compound Het	Parents: Het	0.000297 0.0000892	VUS / VUS	-
Family 8	<i>WFS1</i>	NM_006005.3	c.1538A>G (p.Y513C)	Missense	Het	Maternal	0.000024	Likely Pathogenic	-
Family 9	<i>WFS1</i>	NM_006005.3	c.2603G>A (p.R868H)	Missense	Het	Paternal	0.000092	Likely Pathogenic	215403 / CM165567
Family 10	<i>FYCO1</i>	NM_024513.4	c.265C>T (p.R89C)	Missense	Hom	Parents: Het	0.000123	Likely Pathogenic	425295 / CM1926394
Family 11	<i>GCNT2</i>	NM_001491.3	c.58A>G (p.I20V)	Missense	Het	Paternal	0.0000159	VUS	-
Family 12	<i>LSS</i>	NM_001001438.3	c.1673A>G (p.E558G)	Missense	Hom	Parents: Het	Absent	VUS	-

ACMG: American College of Medical Genetics and Genomics, VUS: uncertain significance variant, HGMD: Human Gene Mutation Database, gnomAD: Genom Aggregation Database, Het: Heterozygous, Hom: Homozygous, PMID: PubMed Identifier.

Discussion

The present research was conducted to investigate the molecular etiology of non-syndromic CC in cases with genetic heterogeneity using WES analysis. In almost two thirds of these families, pathogenic and likely pathogenic variations explaining the etiology of CC were identified. Studies investigating non-syndromic CC cases in varying patient cohorts in different populations have reported varying rates of diagnosis. The diagnosis rate reported in patient cohorts investigated by a targeted next generation sequencing panel or WES analysis range between 42% and 75% (8, 9, 10, and 11). Although the sample size was small in the present research, the diagnosis rate was found to be 58%, and this rate was consistent with the literature. In their study investigating CC cases using whole genome sequencing (WGS), Ma et al. [12] concluded that the rate of diagnosis was 77%, which was 10% higher compared to the rate of diagnosis in WES. Another previous study stated that using WGS will likely increase the diagnosis rates to identify the molecular etiology of relevant cases, as WGS enables the detection of variants in GC-rich regions, indels in repetitive regions, and small copy number variations [12].

In the present research, we found variants in β -crystallin and γ -crystallin genes (*CRYBB2*, *CRYGA*, and *CRYBB1*) in 3 (F1, F2, F3) of the 12 families investigated. A *de novo* missense heterozygous c.355G>A (p.G119R) variant was detected in the *CRYBB2* gene in a 6-month-old male patient (II-2) with bilateral membranous cataract in Family 1. Ma et al. [10] reported this variant for the first time in the literature and identified this variation as a *de novo* variant in a sporadic case. Later on, 3 individuals with nuclear cataract from the same family were found to have the same variant in a study conducted by Chen et al. in familial CC cases [13]. Finally, this variant was also reported by Bell et al. in 2021 as a *de novo* variant in a sporadic case [14]. This variant (c.355G>A; p.G119R) is located on the third Greek key domain of the *CRYBB2* protein. Previous analyses predict that conversion of the hydrophobic glycine amino acid into a hydrophilic arginine amino acid is very likely to affect the three dimensional structure of this protein [10]. In these studies, it was seen that these cases that had the same variation in the same gene had different cataract types. This is supporting evidence for the clinical heterogeneity observed in CC cases. In the present research, we identified a missense heterozygous (c.239G>A; p.R80H) variant in the *CRYGA* gene in the index case in Family 2 and the mother of the

case who had a similar phenotype. In the literature, this variant was identified in previous studies examining CC cases in families and the variation was reported in three individuals from the same family [11]. In the present research, a novel heterozygous in-frame deletion (c.126_128delAAC; p.T43del) in the *CRYBB1* gene was identified in an index case in Family 3 with bilateral posterior polar cataract. Furthermore, it was found that the variant was also present in the mother of this case who had a similar phenotype. This variant is not present in the gnomAD population database and is considered a VUS variant according to ACMG criteria. In the present research, the variation was found to be co-segregated with the disease in the family. However, in order to clarify the pathogenicity of this variant, further experimental studies are needed.

In the present research, two different novel missense variations (c.144_145delGCinsAG; p.Q49E and c.65G>A; p.G22D) were identified in the gene encoding the gap junction alpha-3 protein (GJA3) in two different families (families F4 and F5). These variants were not previously reported in the literature or population databases. According to the ACMG criteria, these two variants are categorized as likely pathogenic. Previous studies in the literature report that the glycine amino acid located in codon 22 of the GJA3 protein is highly phylogenetically conserved among multiple species, and the change of glycine to serine in the same codon leads to the CC phenotype in these patients [15]. It is also reported in the literature that glutamine located in codon 49 is highly phylogenetically conserved among multiple species. These two variations (p.G22D, p.Q49E) are located on the N-terminus/transmembrane domain 1 boundary and first extracellular loop (EC1) domain of the GJA3 protein, respectively. These two domains of the GJA3 protein play a role in pore structure/gating and gap junction formation, respectively [16]. According to our results and supporting literature evidence, it can be speculated that both of these novel variants identified in the *GJA3* gene lead to the CC phenotype.

In 2018, Ansar et al. [17] conducted a study on Pakistani families with CC and identified homozygous loss-of-function variations in the Dynamin-binding protein (*DNMBP*) in 3 different families, and this was the first study in the literature to associate *DNMBP* gene with the CC phenotype. In the present research, a first cousin marriage was observed between the parents in Family 6, and it was found that the index case received the diagnosis of bilateral lamellar cataract at the age of five months. In Family 6, a bi-allelic novel nonsense (c.1918C>T; p.R640*) variant was detected in the *DNMBP* gene in an index case. It was found that both parents in Family 6 were heterozygous for this variant. The present research is the second study in the literature that reports bi-allelic loss-of-function variants in the *DNMBP* gene. In the present study, a 6-month-old patient diagnosed with bilateral lamellar cataract in Family 7 was found to carry maternal c.395G>A (p.G132E) and paternal c.960G>T (p.Q320H) variations in the *DNMBP* gene, and furthermore, there was no consanguinity among the parents of this case. Although both variants were categorized under VUS variants according to ACMG criteria, there is a need for further studies to examine and clarify the pathogenicity of these variants.

Wolframin is a cellular protein located on the endoplasmic reticulum (ER) membrane. Wolframin plays a role in the regulation of membrane trafficking, secretion, and ER calcium homeostasis. Reports in the OMIM database show that *WFS1* gene mutations are associated with Wolfram Syndrome, Wolfram-like syndrome, autosomal dominant deafness, and autosomal dominant cataract phenotypes. Previous studies have so far stated that there are two missense variations in the *WFS1* gene associated with the non-syndromic CC phenotype, and both of these variations are registered in the Cat-Map database [18, 19]. In the present research, two variations were detected in families 8 and 9 and both were considered likely to be pathogenic according to ACMG criteria. Furthermore, these variations were also co-segregated with the disease in the family. In the present research, a missense heterozygous c.2603G>A (p.R868H) variant was detected in the *WFS1* gene in Family 9. In previous studies, this variant was associated with the autosomal recessive hearing loss phenotype. However, in the present research, no additional anomaly was identified in the case except for the presence of cataract.

FYCO1 (FYVE and coiled-coil domain containing 1) protein plays a key role in the transport of microtubule-mediated autophagocytic vesicles in the cell [20]. In the literature, *FYCO1* gene expression has been identified in the lens. Furthermore, literature evidence shows that the absence of this protein leads to the cataract phenotype as a result of elevated levels of reactive oxygen radicals [20]. In the present research, first cousin marriage between parents was identified in Family 10. In this family, it was found that the index case received a diagnosis of bilateral total white cataract at the age of six months. We found a homozygous missense c.265C>T (p.R89C) variant in the *FYCO1* gene in the index case in Family 10 (F10, II-1). This variant reported as likely pathogenic without providing the relevant phenotype information in the ClinVar database. The fact that this variant is likely pathogenic according to ACMG criteria and it was reported to be co-segregated with the disease allows us to speculate that the variant can explain the etiology of the relevant case.

GCNT2 is an autosomal recessive gene that is associated with the CC phenotype and is expressed in erythrocytes and lens cells in the body. To date, studies in the literature have only reported limited numbers of missense, nonsense, and gross exonic deletions in the *GCNT2* gene [21]. In the present research, Family 11 contained two siblings with CC cataract (F11, II-1, II-2) born from parents without any consanguinity. Therefore, possible autosomal recessive inheritance was considered, and the family was thus included in genetic analysis. A paternally inherited novel heterozygous missense c.58A>G (p.I20V) variant was detected in the *GCNT2* gene in siblings with the CC phenotype. This variant was categorized as a VUS variant according to ACMG criteria. Literature evidence shows that bi-allelic *GCNT2* gene variants can lead to the CC phenotype. We can talk about two possibilities in such a case: i) There may be a monoallelic gross exonic deletion or deep intronic variation in the *GCNT2* gene that WES analysis fails to identify, or ii) the CC phenotype of the patients may be associated with another gene which is not revealed by WES analysis.

Literature evidences that there is *LSS* gene expression in the lens. Furthermore, *LSS* encodes lanosterol synthase, which plays a critical role as the rate-limiting enzyme in cholesterol synthesis. Previous reports in the literature show that *LSS* gene variations cause a decrease in cholesterol levels in the lens and lead to cataract development [22]. In the present research, a novel homozygous missense c.1673A>G (p.E558G) variant was detected in *LSS* gene in the proband in Family 12. The amino acid residue is located in a highly conserved region. Therefore, the variation may have an effect on the function of this protein. However, there is a need for further research to elucidate this issue.

There are certain limitations of the present research. i) The sample size was small. This may have had an effect on diagnosis rates and the protein groups in which variations were detected. Therefore, the results may not be generalizable to the entire population. ii) We could not perform a functional study for variants categorized as VUS variants according to ACMG criteria. iii) Due to the technical limitations of WES analysis, we could not investigate gross

deletions/duplications, deep intronic variants, and variants in homopolymer regions in this study. In autosomal recessive genes with monoallelic variant, as in Family 11, the second variant should be studied in the relevant cases. Therefore, it would be beneficial to examine these cases using Multiplex Ligation-dependent Probe Amplification and WGS analysis.

To the best of our knowledge, the present research is one of the limited numbers of studies in the Turkish population in which genetically heterogeneous non-syndromic CC was investigated using WES analysis. Novel variants that we identified in *DNMP*, *LSS*, and *WFS1* genes, which are rarely associated with the CC phenotype, have contributed to the mutation spectrum of this disease. Identifying the relevant molecular genetic etiology allows accurate genetic counseling to be provided to the families.

Declarations

Author contributions

All authors contributed to the study conception and design. Material preparation, data collection and analysis were performed by AT, ATK, SÖY, SGS, SS. Genetic analysis was performed by AT. The first draft of the manuscript was written by AT and all authors commented on previous versions of the manuscript. All authors read and approved the final manuscript.

Funding

The authors did not receive support from any organization for the submitted work.

Data availability

The authors declare that materials described in the manuscript, including all relevant raw data, will be freely available to any scientist wishing to use them for noncommercial purposes, without breaching participant confidentiality. Moreover, the authors ensure that their datasets are presented in the main manuscript.

Conflicts of interest

All the authors declare that they have no conflict of interest and no financial disclosure.

Consent to participate

Informed consent was obtained from legal guardians.

Consent to publish

Additional informed consent was obtained from all legal guardians for whom identifying information is included in this article.

Ethical approval

All procedures performed in studies involving human participants were in accordance with the ethical standards of the institutional and/or national research committee and with the 1964 Helsinki Declaration and its later amendments or comparable ethical standards. The study was approved by the Ethics Committee of the Kartal Dr. Lütfi Kırdar City Hospital, Istanbul, Turkey (decision date: 28 April 2021, No. 2021/514/200/3).

References

1. Sheeladevi S, Lawrenson JG, Fielder AR, Suttle CM (2016) Global prevalence of childhood cataract: a systematic review. *Eye (Lond)* 30:1160-1169.
2. Churchill A, Graw J (2011) Clinical and experimental advances in congenital and paediatric cataracts. *Philos Trans R Soc Lond B Biol Sci* 366:1234-1249.
3. Messina-Baas O, Cuevas-Covarrubias SA (2017) Inherited Congenital Cataract: A Guide to Suspect the Genetic Etiology in the Cataract Genesis. *Molecular Syndromology* 8:58-78.
4. Fernández-Alcalde C, Nieves-Moreno M, Noval S et al (2021) Molecular and Genetic Mechanism of Non-Syndromic Congenital Cataracts. Mutation Screening in Spanish Families. *Genes (Basel)* 12:580.
5. Li H, Durbin R (2010) Fast and accurate long-read alignment with Burrows-Wheeler transform. *Bioinformatics*. 26:589-595.
6. Kopanos C, Tsiolkas V, Kouris A et al (2019) VarSome: the human genomic variant search engine. *Bioinformatics* 35:1978-1980.
7. Richards S, Aziz N, Bale S et al (2015) ACMG Laboratory Quality Assurance Committee. Standards and guidelines for the interpretation of sequence variants: a joint consensus recommendation of the American College of Medical Genetics and Genomics and the Association for Molecular Pathology. *Genet Med* 17:405-424.
8. Gillespie RL, O'Sullivan J, Ashworth J et al (2014) Personalized diagnosis and management of congenital cataract by next-generation sequencing. *Ophthalmology* 121:2124-2137.
9. Lenassi E, Clayton-Smith J, Douzgou S et al (2020) Clinical utility of genetic testing in 201 preschool children with inherited eye disorders. *Genet Med* 22:745-751.
10. Ma AS, Grigg JR, Ho G et al (2016) Sporadic and Familial Congenital Cataracts: Mutational Spectrum and New Diagnoses Using Next-Generation Sequencing. *Hum Mutat* 37:371-384.

11. Javadiyan S, Craig JE, Souzeau E et al (2017) High-Throughput Genetic Screening of 51 Pediatric Cataract Genes Identifies Causative Mutations in Inherited Pediatric Cataract in South Eastern Australia. *G3 (Bethesda)* 7:3257-3268.
12. Ma A, Grigg JR, Flaherty M et al (2021) Genome sequencing in congenital cataracts improves diagnostic yield. *Hum Mutat* 42:1173-1183.
13. Chen P, Chen H, Pan XJ, Tang SZ, Xia YJ, Zhang H (2018) Novel mutations in CRYBB1/CRYBB2 identified by targeted exome sequencing in Chinese families with congenital cataract. *Int J Ophthalmol* 11:1577-1582.
14. Bell S, Malka S, Lloyd IC, Moosajee M (2021) Clinical Spectrum and Genetic Diagnosis of 54 Consecutive Patients Aged 0-25 with Bilateral Cataracts. *Genes (Basel)* 12(2):131.
15. Ye Y, Wu M, Qiao Y, Xie T, Yu Y, Yao K (2019) Identification and preliminary functional analysis of two novel congenital cataract associated mutations of Cx46 and Cx50. *Ophthalmic Genet* 40:428-435.
16. Li B, Liu Y, Liu Y, Guo H, Hu Z, Xia K, Jin X (2016) Identification of a GJA3 Mutation in a Large Family with Bilateral Congenital Cataract. *DNA Cell Biol* 35:135-139.
17. Ansar M, Chung HL, Taylor RL et al (2018) Bi-allelic Loss-of-Function Variants in DNMBP Cause Infantile Cataracts. *Am J Hum Genet* 103:568-578.
18. Berry V, Gregory-Evans C, Emmett W, Waseem N, Raby J, Prescott D, Moore AT, Bhattacharya SS (2013) Wolfram gene (WFS1) mutation causes autosomal dominant congenital nuclear cataract in humans. *Eur J Hum Genet* 21(12):1356-1360.
19. Rechsteiner D, Issler L, Koller S et al (2021) Genetic Analysis in a Swiss Cohort of Bilateral Congenital Cataract. *JAMA Ophthalmol* 139:691-700.
20. Pankiv S, Alemu EA, Brech A et al (2010) FYCO1 is a Rab7 effector that binds to LC3 and PI3P to mediate microtubule plus end-directed vesicle transport. *J Cell Biol* 188:253-269.
21. Borck G, Kakar N, Hoch J et al (2012) An Alu repeat-mediated genomic GCNT2 deletion underlies congenital cataracts and adult i blood group. *Hum Genet* 131:209-216.
22. Zhao L, Chen XJ, Zhu J et al (2015) Lanosterol reverses protein aggregation in cataracts. *Nature* 523:607-611.

Figures

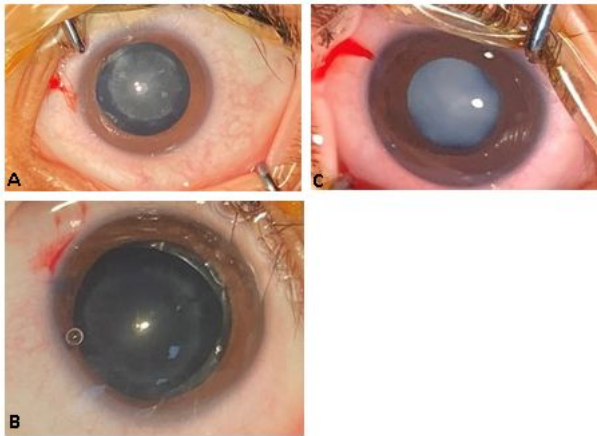

Figure 1

a) Nuclear cataract (Family 12, II-1) b) Lamellar cataract (Family 6, II-1) c) Total white cataract (Family 10, II-1)

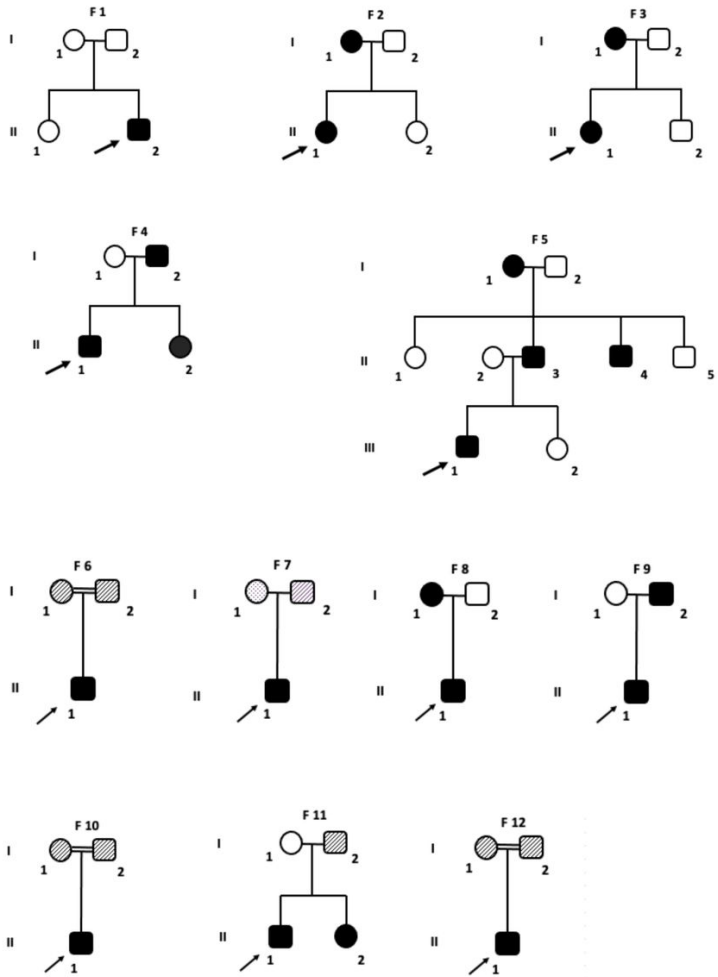

Figure 2

Pedigrees of the congenital cataract families. F: family, Those indicated by black solid fill show probands. Those indicated by the pattern fill show heterozygous (carrier) parents.