

# Nutrient sequestration and lipid production potential of *Chlorella vulgaris* under pharmaceutical wastewater treatment: Experimental, optimization, and prediction modeling studies

**Sonika Kumari**

Gurukul Kangri (Deemed to be University)

**Vinod Kumar**

Gurukul Kangri (Deemed to be University)

**Richa Kothari** (✉ [richakothari786@gmail.com](mailto:richakothari786@gmail.com))

Central University of Jammu

**Pankaj Kumar**

Gurukul Kangri (Deemed to be University)

---

## Research Article

**Keywords:** *Chlorella* sp., Ganga River, Lipid production, Pharmaceutical industry wastewater, Phycoremediation

**Posted Date:** June 21st, 2022

**DOI:** <https://doi.org/10.21203/rs.3.rs-1726808/v1>

**License:** © ⓘ This work is licensed under a Creative Commons Attribution 4.0 International License. [Read Full License](#)

---

## Abstract

The efficient management and treatment of pharmaceutical industry wastewater (PIWW) have become a serious environmental issue due to its high toxicity. To overcome this problem, the present study deals with the phycoremediation of PIWW using *Chlorella vulgaris* microalga isolated from the Ganga River at Haridwar, India. For this, response surface methodology (RSM) and artificial neural network (ANN) tools were used to identify the best reduction of total phosphorus (TP) and total Kjeldahl's nitrogen (TKN) based pollutants along with lipid production efficiency of *C. vulgaris*. Three different concentrations of pharmaceutical wastewater (0, 50, and 100%), operating temperatures (20, 25, and 30°C), and light intensity (2000, 3000, and 4000 lx) were used to design the phycoremediation experiments. Findings revealed that *C. vulgaris* was good enough to remove maximum TP (90.35%), TKN (83.55%) along 20.88% of lipid yield at 25.62°C temperature, 60.73% PIW concentration, and 4000 lx of light intensity, respectively. Based on the model performance and validation results, ANN showed more accuracy as compared to the RSM tool. Therefore, the findings of this study showed that *C. vulgaris* is capable of treating PIWW efficiently along with significant production of lipid content which can further be used in various applications including biofuels production.

## Statement Of Novelty

This study deals with the use of algal-based technology for the bio-treatment of the pharmaceutical industry wastewater and attendant biomass characterization. A novel *Chlorella vulgaris* strain (NIES-xx) was isolated from the Ganga River at Haridwar, India, and further tested for its bioremediation efficiency. For this, RSM and ANN modeling tools were used to predict pollutant reduction and algal biomass production. The comparative analysis showed that the ANN method was more suitable for the prediction of treatment performance as compared to RSM. Previously, no study has reported the exploitation of *C. vulgaris* isolated from the Ganga River for wastewater reclamation, thus, the current work is novel and provides significant findings on sustainable management of pharmaceutical wastewaters that cause several environmental damages.

## 1. Introduction

Today, the management of industrial wastewater has become one of the prime issues of planet earth (Shrestha et al. 2017). It has been estimated that nearly 80% of global wastewater is disposed of untreated which later creates environmental pollution (Cong and Yu 2018). Parallely with the growth of the industrial sector, the requirement for freshwater has also increased vis versa. However, modern man has to deal with various diseases driven by lifestyle and sedentary life (Egger et al. 2017). To deal with these diseases, certain drugs are required, and here comes the role of the pharmaceutical industry. The pharmaceutical sector produces a variety of medicines like antibiotics, herbal medicines, sedatives, hormone-based, pills, etc. of human and veterinary importance. To meet the increasing demands of the population, recently the number of pharmaceutical industries has increased, drastically (Patil 2016).

In order to manufacture certain drugs, the pharmaceutical industry utilizes a wide variety of raw materials including natural, synthetic and biological. In this, active pharmaceutical ingredients (APIs) also called bulk drugs are the key ingredients used in medicine manufacturing. APIs are water persistent, biochemically active chemical compounds (Pudasaini et al. 2017). Besides this, water is also used in various industrial processes such as manufacturing, cleaning, washing, etc. The pharmaceutical industry wastewater (PIWW) has a complex composition, therefore difficult to treat. Generally, it contains high chemical oxygen demand (COD), salt content, residual drugs, and organic compounds (Shah and Shah 2020). Therefore, the pharmaceutical industries produce highly toxic wastewater which is hard to manage using conventional treatment technologies (Dar et al. 2017; Dixit and Parmar 2013). However, the level of pollution and volume of wastewater generated depends on the type and size of the industry. In low-wage countries, most of the industrial wastewater is discharged without adequate treatment (Cong and Yu 2018) which results in environmental pollution, disrupting the normal functioning of aquatic flora and fauna by increasing the nutrient loads of water bodies thereby causing eutrophication. PIWW may induce mutagenic effects upon entering the food chain via different routes (Sboichakov and Reshetnikova 2020). Therefore, the proper and safe management of industrial wastewater is the need of the hour (Maitiyet al. 2021).

Phycoremediation technology involves the use of algae to remove pollutants from wastewaters (Fayyad et al. 2020). Phycoremediation technology is more proficient in the treatment of wastewaters rather than that of physical and chemical methods (Sharma et al. 2020). Out of several algal species utilized for phycoremediation purposes, *Chlorella vulgaris* is a green-colored unicellular eukaryotic microalga having a thick cell wall. It is one of the widely studied members of the Chlorophyceae family. It has a fast growth rate and capability to grow in most of the nutrient stressed mediums including contaminated water bodies also (Zhu et al. 2020). In order to provide resistance to stressed environments, the thick cell wall of *C. vulgaris* mediates certain chemical and mechanical processes for its efficient survival (Sydney et al. 2019). *C. vulgaris* is reported to have a proficient ability to remove biological oxygen demand (BOD), chemical oxygen demand (COD), phosphorous and nitrogen-based pollutants from wastewaters within short periods (Azizi et al. 2020). Previously, various successful studies have been done on the bioremediation efficiency of *C. vulgaris* using different types of wastewaters such as domestic (Miao et al. 2016), municipal (Znad et al. 2018), synthetic (Lee et al. 2020), and petrochemical and textile (Subashini and Rajiv 2018) wastewaters. Algal biomass is a rich source of lipids, proteins, pigments, and vitamins which can be utilized in various applications such as making nutrition supplements, food products, pharmaceuticals. Along with phycoremediation application, algae are also known for their lipid production efficiency (Mao et al. 2020). Recently, algal lipids are in great demand for the production of biofuels having good fatty acid profiles (Hess et al. 2018; López et al. 2019).

The Ganga River is a sacred water body for Hindus that flows from the Himalayas to the Bay of Bengal within the Indian subcontinent. Its freshwater has a great diversity of flora and fauna including *Chlorella* sp. The biological diversity present in the river water helps to maintain its water quality through nutrient sequestration (Zhang et al. 2019). From the previously available literature, it is evident that *C. vulgaris* has the ability to grow in different types of wastewaters including PIWW by utilizing the nutrients available (Bansal et al. 2018). Therefore, *C. vulgaris* can be used for phycoremediation of PIWW along with the potential application of lipid production. Apart from the wastewater type, various environmental conditions (light intensity, temperature) also

affect the growth of algal species. Therefore, there optimization using different statistical tools and mathematical models is crucial in order to maximize the wastewater treatment efficiency of *C. vulgaris* (Liyanaarachchi et al. 2021). For this, response surface methodology (RSM) and artificial neural network (ANN) are statistical approaches extensively used to maximize the outputs by optimizing the operational variables (Zhang and Huang 2015; Sabour and Amiri 2017).

As aforementioned, considering the problems associated with the management of PIWW, the present study has been designed to assess the phycoremediation efficiency of isolated *Chlorella vulgaris* alga under different levels of wastewater loads, temperature, and light intensities. The findings are supported using two different types of optimizations and prediction modeling i.e., response surface methodology (RSM) and artificial neural network (ANN) tools.

## 2. Material And Methods

### 2.1. Organism used

Being a freshwater resource, *Chlorellavulgaris* naturally occurs in the Ganga River which helps in nutrient sequestration and works as a feedstock for several macro-and microbenthic organisms (Beuckels et al. 2015). For the present experiment, *C. vulgaris* (NIES:227) microalgae were isolated from the disposal point of Jagjeetpur Sewage Treatment Plant (STP) situated near the Ganga River at Haridwar, India (29°53'58.6"N and 78°08'28.9"E). The morphological identification of *C. vulgaris* (NIES:227) was done by using digital microscope (Optika, B-383PLI, IN) following Bellinger and Sigeo (2015) identification keys and that of genetic identification by 28s rRNA. For the sequencing ABI PRISM® BigDye™ Terminator Cycle Sequencing Kits with AmpliTaq® DNA polymerase (FS enzyme) (Applied Biosystems) was used and it was further purified by ABI 3730xl sequencer (Applied Biosystems) (Talavera and Castresana, 2007). The screened algal culture was replicated and maintained on sterile BG-11 medium under controlled environmental conditions. The composition of BG-11 medium includes 40 mL solution of each of NaNO<sub>3</sub> (150 g/L), K<sub>2</sub>HPO<sub>4</sub> (4.0 g/L), MgSO<sub>4</sub>·7H<sub>2</sub>O (7.5 g/L), CaCl<sub>2</sub>·2H<sub>2</sub>O (3.6 g/L), citric acid (0.60 g/L), ammonium ferric citrate green (0.60 g/L), EDTA (0.1 g L<sup>-1</sup>), Na<sub>2</sub>CO<sub>3</sub> (2 g/L) and 1 mL of each micronutrients solution [2.85 g/L H<sub>3</sub>BO<sub>3</sub>, 1.81 g/L MnCl<sub>2</sub>·4H<sub>2</sub>O, 0.22 g/L ZnSO<sub>4</sub>·7H<sub>2</sub>O, 0.39 g/L Na<sub>2</sub>MoO<sub>4</sub>·2H<sub>2</sub>O, 0.08 g/L CuSO<sub>4</sub>·5H<sub>2</sub>O, and 0.05 g/L Co(NO<sub>3</sub>)<sub>2</sub>·6H<sub>2</sub>O] in a 2L Erlenmeyer flask to make 1000mL of stock solution.

### 2.2. Collection of pharmaceutical industry wastewaters

In the present study, pharmaceutical industry wastewater (PIWW) was collected from Unicare India Pvt. Ltd situated at Bhagwanpur, Haridwar, India (29°57'14.2"N and 77°48'00.1"E). The wastewater samples were collected in 20 L capacity non-reactive polyvinyl chloride (PVC) containers. The samples were transported to the laboratory and stored at 4°C until further utilization in the phycoremediation experiments.

### 2.3. Experimental design and conditions

The phycoremediation experiments were carried out in the Agro-ecology and Pollution Research laboratory of Department of Zoology and Environmental Science, Gurukul Kangri (Deemed to be University), Haridwar, India (29°55'11.9"N and 78°07'09.7"E). In this regard, Design-Expert software (Stat-Ease, USA) was used for obtaining the suggested design matrix (16 experimental trials). Glass aquariums (25×30×28 cm; length×height×width) of 20 L capacity were used as photo-bio-reactor. For the optimization experiments, a total of three control variables i.e., pharmaceutical wastewater concentration (A: 0, 50, and 100%), reactor temperature (B: 20, 25, and 30°C), and light intensity (C: 2000, 3000, and 4000lx) were used to optimize the total phosphorous (Y<sub>1</sub>: TP; %), total Kjeldahl's nitrogen (Y<sub>2</sub>: TKN; %) and lipid production (Y<sub>3</sub>: %) efficiency of isolated *C. vulgaris*, respectively (Table 1). Purposely, wastewater concentration was adjusted using the addition of borewell water (BWW) to achieve high (+1) and medium (0) levels. The glass reactors were filled with a 15 L working volume of pharmaceutical wastewater followed by the addition of 150 mL stock algal culture (cell density 0.375 g/L). The experimental layout of the glass bioreactor used for *C. vulgaris* cultivation is given in Fig. 1. The glass reactors were equipped with a 150W aquarium heater and light-emitting diodes (LED-white) bulb (2W G4, VRCT, IN) for controlling the temperature and light intensity (calibrated using digital LUX meter; LX-1010B, MEXTECH, IN), respectively. *C. vulgaris* was provided with 6 hrs dark and 18 hrs light period till 16th days.

Table 1  
Design of the independent and dependent variables used for the central composite design of response surface methodology.

Variable	Unit	Coded term	Levels		
			Low (-1)	Medium (0)	High (+1)
Wastewater concentration	%	A	0	50	100
Temperature	°C	B	20	25	30
Light intensity	lx	C	2000	3000	4000
TP removal	%	Y <sub>1</sub>	-		
TKN removal	%	Y <sub>2</sub>	-		
Lipid production	%	Y <sub>3</sub>	-		

## 2.4. Mathematical models for optimization and prediction studies

Nowadays, mathematical models are being widely used to optimize the bioremediation of industrial effluents. In this, response surface methodology (RSM) and artificial neural network (ANN) are some of the most feasible tools which can be used to maximize the pollution reduction efficiency of bioremediation systems (Seragadam et al.2021). In the present study, the experimental trials were randomly organized according to the face-centered (k = 1) central composite design (CCD) of response surface methodology (RSM). The prediction and optimization of the developed RSM model were done by using the following quadratic model (Eq. 1):

$$Y = \beta_0 + (\beta_a A) + (\beta_b B) + (\beta_c C) + (\beta_{ab} AB) + (\beta_{ac} AC) + (\beta_{bc} BC) + (\beta_a A^2) + (\beta_b B^2) + (\beta_c C^2) \text{ Eq. (1)}$$

Where,  $Y$  is the optimizable response variables in terms of TP/TKN removal and lipid production,  $\beta_0$ ,  $\beta_a$ ,  $\beta_b$ , and  $\beta_c$  are the estimated quadratic regression coefficients, while  $A$ ,  $B$ , and  $C$  correspond to wastewater concentration, reactor temperature, and light intensity, respectively.

On the other hand, a feed-forward and back-propagation (FFBP) method of ANN was used to construct the prediction model based on the variables given in Table 1. The ANN model was composed of three different layers including, the input layer (3 neurons), hidden layer (10 neurons), and output (1 neuron) as given in Fig. 2. The dataset was divided into three different groups *viz.*, 70, 15, 15% referring to training, testing, and validation groups, respectively. The maximum number of epochs tested during the model training was 100. The output layer corresponds to the response variable *i.e.*, TP/TKN removal and lipid production. For this, the "nntool" module of MATLAB 2020b (MathWorks, USA) was used.

Moreover, the prediction feasibility of both RSM and ANN models was estimated using the minimum difference between a measure and predicted response values and coefficient of determination ( $R^2$ ) tools (Eq. 2).

$$R^2 = 1 - \frac{\sum (y_i - \hat{y})^2}{\sum (y - \bar{y})^2} \text{ Eq. (2)}$$

The validation of the models was carried out using mean square error (MSE) and root mean square error (RMSE) tools as per the following formula (Eq. 3–4):

$$MSE = \frac{1}{N} \sum_{i=1}^n (y_i - \hat{y})^2 \text{ Eq. (3)}$$

$$RMSE = \sqrt{MSE} = \sqrt{\frac{1}{N} \sum_{i=1}^n (y_i - \hat{y})^2} \text{ Eq. (4)}$$

Where  $\hat{y}$  and  $\bar{y}$  are predicted and mean values of  $y$  response variable while  $N$  is the number of observations, respectively (Kim et al. 2019).

## 2.5. Wastewater analytical methods

In this study, the water and wastewater samples were analyzed for selected physicochemical and nutrient parameters such as pH, electrical conductance (EC: dS/m), total dissolved solids (TDS: mg/L), total Kjeldahl's nitrogen (TKN: mg/L), total phosphorus (TP: mg/L), magnesium (Mg: mg/L), sodium (Na: mg/L), calcium (Ca: mg/L) and potassium (K: mg/L) following standard methods (AOAC 2005; APHA 2012) (Table 2). Purposely, a microprocessor-based digital multi-meter (1615, ESICO, IN) was used for pH, EC, and TDS estimation. The Spectrophotometric (Agilent Cary 60, USA) method was used for TP and COD analysis whereas the contents of K and Na were analyzed using the flame photometric method (1382, ESICO, IN). Moreover, TKN was determined by using Kjeldahl's acid-digestion and distillation method. Despite this, the titrimetric method was used for the determination of Ca and Mg contents. Laboratory grade reagents procured from Sigma-Aldrich (IN) were used in all chemical analyses of this experiment.

Table 2  
Physicochemical characteristics of borewell water and pharmaceutical industry wastewater.

Characteristics	Borewell water	Pharmaceutical wastewater	Unit	Standard for inland discharge (BIS, 2009)
Odor	Odorless	Pungent	-	-
Color	Colorless	Blackish	-	-
pH	7.62 ± 0.01	6.80 ± 0.40*	-	5.50-9.00
Electrical conductivity	0.33 ± 0.03	0.60 ± 0.02*	dS/m	-
TDS	114.35 ± 7.62	940.34 ± 12.42*	mg/L	-
TKN	4.12 ± 0.03	825.12 ± 52*	mg/L	100.00
TP	2.57 ± 0.19	215.32 ± 13.05*	mg/L	5.00
Na	5.16 ± 0.24	184.08 ± 3.12*	mg/L	-
K	2.58 ± 0.03	159.04 ± 1.23*	mg/L	-
Ca	4.28 ± 0.26	69.5 ± 1.05*	mg/L	-
Mg	5.14 ± 0.02	23.6 ± 0.11*	mg/L	-

Values are mean followed by standard deviation of three analyses; \*: statistically significant at P < 0.05; BIS: Bureau of Indian Standards.

## 2.6. Determination of pollution removal efficiency and lipid content

The efficiency of selected *C. vulgaris* in the removal of TP and TKN pollutants from pharmaceutical wastewater was enumerated based on the pollutant removal efficiency index (Re: %). The form of the formula (Eq. 5) is given below (Faizet al. 2017):

$$\text{Removal efficiency (\%)} = \left( \frac{C_0 - C_t}{C_0} \right) \times 100 \text{ (Eq. 5)}$$

Where  $C_0$  and  $C_t$  were the initial and residual (after t time) concentrations of TP and TKN of pharmaceutical wastewater.

On the other hand, the cultivated algal biomass was harvested through anhydrous  $\text{Al}_2(\text{SO}_4)_3$ -flocculation method (150 mg/L; 100 rpm; 5 min). Further, the harvested algal biomass was used for lipid extraction using the Soxhlet method. For this, n-hexane was used as an extraction solvent under a total of 10 cycles at 70°C for 1 h. The quantification of the extracted lipids was done by calculating the weight of lipids left after the evaporation of extraction solvent used i.e., n-hexane. Finally, the lipid content was estimated using the gravimetric method as previously described by Karpagam et al. (2015).

## 2.7. Software and statistics

For the present study, different software packages such as Design Expert (12, State Ease, USA), Microsoft Excel (2019, Microsoft Corp, USA), MATLAB (MathWorks Inc., USA), and OriginPro (2021b, Origin Corp., MX), etc. were used for experimental designing, statistical, modeling, and graphical works. All experiments were performed as triplicated random design and the level of statistical significance was adjusted to prob. (P) < 0.05.

## 3. Results And Discussion

### 3.1. Characteristics of borewell water and pharmaceutical industry wastewater

Table 2 provides the physicochemical and nutrient parameters of PIWW and BWW used for phycoremediation experiments. Results indicated that BWW contains a lesser pollution load than that of PIWW used in this study. In general, values of various physicochemical and nutrient parameters of BWW viz., EC (0.33 ± 0.03 dS/m), pH (7.62 ± 0.01), BOD (2.56 ± 0.24 mg/L), COD (5.76 ± 0.59 mg/L), TDS (114.35 ± 7.62 mg/L), TKN (4.12 ± 0.03 mg/L), TP (2.57 ± 0.19 mg/L), Mg (5.14 ± 0.02 mg/L), Na (5.16 ± 0.24 mg/L), Ca (4.28 ± 0.26 mg/L) and K (2.58 ± 0.03 mg/L) were significantly lower (P < 0.05) as compared to PIWW which had EC (0.6 ± 0.02 dS/m), pH (6.8 ± 0.4), BOD (9435.2 ± 549 mg/L), COD (15423.6 ± 1121 mg/L), TDS (940.34 ± 124 mg/L), TKN (825 ± 52 mg/L), TP (215 ± 13 mg/L), Mg (23.6 ± 0.11 mg/L), Na (184.08 ± 3.12 mg/L), Ca (69.5 ± 1.05 mg/L) and K (159.04 ± 1.23 mg/L) contents much higher, respectively. The sources of various pollutants in pharmaceutical wastewater might be the residual chemicals during drug production. While the nutrients might be the result of the processing and manufacturing of herbal medicines using plant-based raw materials.

The above findings suggest that the discharge of improperly treated PIWW in water bodies may lead to several environmental issues in the study province including arable land pollution, pollutant accumulation in aquatic bodies, etc. Therefore, there is an urgent necessity to implement efficient PIWW treatment technologies before discharging them in the open environment. Studies from the past few years showed that being rich in several nutrients, PIWW can be utilized in algal cultivation. Out of them, Pal (2018) studied the physicochemical and nutrient parameters of PIWW that contained several organic and inorganic nutrients. Hence, the physicochemical and nutrient profile of PIWW used in this study showed that it can be used as a nutrient medium for algal growth.

### 3.2. Phycoremediation and lipid production efficiency of isolated *C. vulgaris*

In this study, the isolated *C. vulgaris* was efficient enough for the phycoremediation of PIWW in terms of TP/TKN removal and lipid production. Table 3 depicts the results of PIWW phycoremediation experiments conducted using the CCD method of RSM. In this, varied ranges of TP/TKN removal and lipid yield were seen amongst different experimental trials while considering the control. More specifically, the highest reduction of TP and TKN was observed as 91.11 and 82.41%, respectively using 50% wastewater concentration. Other than this, the maximum lipid yield was 20.6% extracted using the Soxhlet extraction method (Fig. 4).

**Table 3.** Comparative analysis of RSM and ANN (central composite design matrix) for the phycoremediation of pharmaceutical industry wastewater using *C. vulgaris*

Run No.	Factors			Responses								
	PWW Conc. (A: %)	Temp. (B: °C)	Light intensity (C: lx)	TP removal (Y <sub>1</sub> : %)			TKN removal (Y <sub>2</sub> : %)			Lipid production (Y <sub>3</sub> : %)		
				Measured	RSM Predicted	ANN Predicted	Measured	RSM Predicted	ANN Predicted	Measured	RSM Predicted	ANN Predicted
1	50 <sup>M</sup>	25 <sup>M</sup>	4000 <sup>H</sup>	91.11	88.60	89.78	82.41	81.90	77.00	20.60	20.47	20.58
2	50	25	2000 <sup>L</sup>	82.08	82.28	81.53	80.35	78.06	80.35	20.08	19.51	20.08
3	0 <sup>L</sup>	20 <sup>L</sup>	2000	25.26	23.13	24.59	23.55	22.35	21.56	5.88	5.58	5.75
4	0	30	4000	34.64	35.03	34.77	30.92	31.05	30.92	7.73	7.76	7.73
5	50	30 <sup>H</sup>	3000 <sup>M</sup>	80.30	78.63	81.07	72.76	71.46	71.06	18.19	17.86	18.13
6	100 <sup>H</sup>	25	3000	68.35	64.17	63.42	61.02	57.02	61.02	15.25	14.25	14.18
7	100	20	4000	61.63	61.69	60.39	55.02	54.68	55.02	13.75	13.66	13.72
8	0	20	4000	29.03	28.38	29.00	25.91	24.74	25.91	6.47	6.18	13.45
9	100	20	2000	57.06	57.24	57.00	50.94	51.51	50.94	12.73	12.87	13.40
10	50	25	3000	79.27	83.89	79.98	70.77	76.37	82.15	17.69	19.09	17.68
11	0	25	3000	31.39	33.26	30.97	28.02	29.22	28.04	7.00	7.30	7.00
12	50	30	3000	81.80	78.63	81.07	75.10	71.46	71.06	18.77	17.86	18.13
13	100	30	2000	54.14	55.37	54.26	50.33	52.20	50.33	12.58	13.05	12.65
14	0	30	2000	26.33	26.85	27.21	25.50	26.54	25.52	6.37	6.63	6.31
15	50	20	3000	73.71	76.24	72.93	65.81	67.95	65.81	16.45	16.98	16.45
16	100	30	4000	60.04	62.75	60.11	55.60	57.50	55.02	13.90	14.37	14.07

L: low level; M: medium level; H: high level; PIWW: pharmaceutical industry wastewater; RSM: response surface methodology; ANN: artificial neural network.

Generally, TP and TKN are the major nutrients that are extremely necessary for the growth and reproduction of living organisms including algal cells. TP plays an important role in the formation of genetic material while TKN is required for amino acid, lipid, and protein synthesis. Algae are evolved to utilize these nutrients from water bodies and grow simultaneously. However, they can survive up to a certain level of TP and TKN nutrients. That might be the reason why a slight growth inhibition was observed using absolute PIWW treatment which contained high TP and TKN loads. Thus, the optimum is the nutrient uptake, greater will be for the algal biomass and lipid production (Escapa et al. 2017).

There are very limited studies on the phycoremediation of PIWW using algal species. However, no study focused on TP and TKN removal by *C. vulgaris* using the RSM-CCD method. A report by Xionget al. (2017) investigated multiple exposures of *C. vulgaris* to levofloxacin contaminated PIWW. Their findings showed that the biodegradation of levofloxacin improved significantly after acclimation. Besides this, Nayak and Ghosh (2019) also studied the phycoremediation efficacy of *Scenedesmus abundans* using PIWW under 21 days of hydraulic retention time. They observed that the contents of nitrate and phosphate were significantly removed by 97.12 and 93.71% along with  $0.97 \pm 0.01$  g/L of biomass production, respectively. The cultivated algal biomass had a good fatty acid profile which can be further used for secondary purposes such including bioenergy production.

### 3.3. Effects of different control variables on *C. vulgaris* performance

#### 3.3.1. Effect of pharmaceutical industry wastewater concentration

The PIWW concentrations as a control variable, significantly ( $P < 0.0001$ ) affected all the three response variables viz., TP/TKN removal, and lipid yield, respectively. The results of the CCD matrix given in Table 3 showed that medium level (0) of PIWW concentration i.e., 50% gave the maximum pollutant removal along with the highest production of lipid yield. However, the growth of isolated *C. vulgaris* was slightly retarded using a high dose (+1) of PIWW (100%). The absolute PIWW contained a high load of TP and TKN nutrients which might not be feasible for efficient algal growth experiments. Since the

alga was isolated from the confluence points between freshwater and polluted water environments, thus it might have been adopted to grow under a nutrient-stressed environment up to an optimum level. On the other hand, the lowest growth in control i.e., 0% PIW may be due to the lesser availability of nutrients in borewell water.

Recently, Madadi et al. (2021) analyzed *C. vulgaris* growth potential in their experiments on phycoremediation of petrochemical wastewater. The most feasible concentration was 50% resulting in the highest concentration of lipid production. However, the removal of nutrients showed varied trends such as 25% dilution for P removal and 50% removal for remaining parameters including BOD. This report showed that the P tolerance of *Chlorella* sp. was much higher as compared to other pollutants. Our results are also in-line with their findings as TP removal in 50% PIW dilution was 91.11% as compared to TKN 82.41%. Another study by Singh et al. (2017) investigated the nutrient removal efficiencies of *C. vulgaris* cultivated under different dilutions of urban wastewater such as 10, 20, 30%. They observed that maximum nutrient removal was achieved using 30% dilution i.e., 87.9% (from 59.31 to 9.61 mg/L) and 98.4% (7.14 to 0.15 mg/L) for N and P, respectively. This report also supported our results as PIWW concentration was one of the most deterministic factors which affected the removal of pollutants along with lipid production.

### 3.3.2. Effect of reactor temperature

Temperature is one of the major factors which strongly affect the rate of biochemical changes happening within the algal cells (Duan et al. 2018). In the present study, we observed that out of the three applied temperatures viz., 20, 25, and 30 °C, the highest algal growth was found at 25°C. The growth of isolated *C. vulgaris* exponentially increased from 20 to 25°C while it again reduced up to 30°C. The reactor performance was robust at 25°C in terms of TP and TKN removal along with the highest production of lipid content within algal cells. The interactive effect of temperature on growth performance and pollutant reduction of selected *C. vulgaris* is given in Fig. 3. Temperature as a climatic parameter affects the diversity and composition of aquatic microorganisms. The phytoplankton is one of the most dominating microbial communities of the Ganga River. *C. vulgaris* is also one of the commonly found microorganisms which act as food for upper trophic levels. It is found that *C. vulgaris* can grow most efficiently within a temperature range of 23–26°C. Therefore, its in-situ cultivation should also be done under such conditions which mimic its natural temperature environments.

In the previous reports, the effect of temperature on the growth performance of *Chlorella* sp. is widely investigated. However, its response under PIWW treatment using different temperature ranges has not been done to date. In a study, Asadi et al. (2019) assessed the effect of temperature on two algal species viz., *C. vulgaris* and *C. sorokiniana*. The best performance of *C. vulgaris* and *C. sorokiniana* was observed within a temperature range of 25–28°C, respectively. During their experiment, Bamba et al. (2015) studied the effect of temperature ranges (25 to 35 °C) and CO<sub>2</sub> delivery rate (2%) on biomass production, pH, and nitrate removal by *C. vulgaris*. They found that at 25 and 30°C temperature ranges the maximum biomass production of 950 ± 12 and 1000 ± 15 mg/L, and nitrate consumption of 42.5 and 44.2%, were achieved after 12 days, respectively.

### 3.3.3. Effect of reactor light intensity

Light intensity is an important growth parameter and has a direct impact on the growth performance of alga. It is one of the major requirements since green algae require light to undergo photosynthesis (Badar et al. 2018). This study investigated the optimization of three different light intensities viz., 2000, 3000, and 4000 lx using RSM in order to identify the best growth conditions for the *C. vulgaris*. From the results, it was evidenced that algal growth was positively correlated to light intensity up to saturation point i.e., increases from 2000 to 4000 lx. The artificial LED light was sufficient to grow *C. vulgaris* without any restricted growth. The factor-response interaction study showed that the light intensity showed an exponential effect on lipid production and TP/TKN removal. However, light intensity as a control variable showed a moderately significant effect ( $P < 0.1586$ ) compared to PIWW concentration ( $P < 0.0001$ ) and reactor temperature ( $P < 0.3325$ ) (Table 4). The 3D-surface plots given in Fig. 3 also revealed that the light intensity showed an inclining trend of lipid production and TP/TKN removal from 2000 to 4000 lx, respectively.

Table 4  
ANOVA results of the quadratic model used for the phycoremediation of pharmaceutical industry wastewater using *C. vulgaris*

Response	Variable	SOS	F-value	P-value	Remarks	R <sup>2</sup>	Pred. R <sup>2</sup>
TP removal ( $Y_1$ : %)	Model	7660.93	62.15	< 0.0001	*	0.9890	0.9282
	A	2389.19	174.45	< 0.0001			
	B	15.21	1.11	0.3325			
	C	99.73	7.28	0.0356			
	AB	15.65	1.14	0.3262			
	AC	0.3240	0.0237	0.8828			
	BC	4.31	0.3145	0.5952			
	A <sup>2</sup>	3464.89	252.99	< 0.0001			
	B <sup>2</sup>	122.88	8.97	0.0242			
	C <sup>2</sup>	6.70	0.4896	0.5103			
	Lack of fit	81.05	14.41	0.1973	ns		
TKN removal ( $Y_2$ : %)	Model	6439.65	50.34	< 0.0001	*	0.9869	0.9253
	A	1932.38	135.95	< 0.0001			
	B	32.81	2.31	0.1795			
	C	36.83	2.59	0.1586			
	AB	6.11	0.4297	0.5365			
	AC	0.3081	0.0217	0.8878			
	BC	2.26	0.1588	0.7040			
	A <sup>2</sup>	3095.12	217.75	< 0.0001			
	B <sup>2</sup>	130.80	9.20	0.0230			
	C <sup>2</sup>	36.54	2.57	0.1600			
	Lack of fit	82.55	6.03	0.2993	ns		
Lipid production ( $Y_3$ : %)	Model	402.60	50.54	< 0.0001	*	0.9870	0.9256
	A	120.83	136.50	< 0.0001			
	B	2.07	2.33	0.1775			
	C	2.31	2.61	0.1571			
	AB	0.3828	0.4325	0.5352			
	AC	0.0190	0.0215	0.8883			
	BC	0.1431	0.1617	0.7016			
	A <sup>2</sup>	193.48	218.57	< 0.0001			
	B <sup>2</sup>	8.16	9.22	0.0229			
	C <sup>2</sup>	2.28	2.58	0.1596			
	Lack of fit	5.14	6.12	0.2973	ns		

SOS: sum of squares; A: pharmaceutical wastewater conc. (%); B: temp. (°C); C: light intensity (lx). \* and ns: Statistically significant and not significant at  $P < F$  of 0.05.

Numerous studies support the effect of light intensity on algal growth. In a study by Metsoviti et al. (2020), an increase in light intensity from white to the red LED lamps (130 to 520  $\mu\text{mol photons/m}^2/\text{s}$ ) has resulted in a faster growth rate of *C. vulgaris*, along with an increase in lipid content from 7.9–22.2%, respectively. Similarly, Chang et al. (2016) in their experiment optimized the light intensity to achieve maximum biomass production and specific growth rate. They concluded that *C. vulgaris* showed maximized biomass production and growth rate at a light intensity of 120  $\mu\text{mol/m}^2/\text{s}$ .

### 3.4. Comparative assessment of RSM and ANN prediction models



Optimization modeling using RSM and ANN is one of the most commonly used tools to maximize the desired processes using different control variables (Sabour and Amiri 2017). In our study, the phycoremediation efficiency of isolated *C. vulgaris* was tested using three different reactor control factors as the independent variable (*A*: PIWW concentration, *B*: reactor temperature, and *C*: light intensity). The effect of these parameters was investigated in order to maximize the TP/TKN removal and lipid production of *C. vulgaris*. For this, a quadratic model was constructed for the prediction and optimization of the desired response. On the other hand, the ANN architect having three different layers was also used for predicting the same response variables.

The findings of this study revealed that both the RSM and ANN models were efficient in predicting the TP/TKN removal and lipid production of *C. vulgaris*. In this, the comparative analysis results shown in Table 5 showed that ANN models had relatively higher values of coefficient of determination ( $R^2 > 0.9894$ ), lesser MSE ( $< 1.976$ ), RMSE ( $< 1.406$ ) as compared to RSM models which had a coefficient of determination ( $R^2 > 0.9870$ ), lesser MSE ( $< 5.330$ ), RMSE ( $< 2.309$ ), respectively. The RSM models had a highly significant P value i.e.,  $< 0.0001$  for all three responses. The following quadratic equations can be used for the maximization of TP/TKN removal and lipid production of *C. vulgaris* grown in PIWW:

Table 5  
Prediction performance and validation analyses of RSM and ANN models for the phycoremediation of pharmaceutical industry wastewater using *C. vulgaris*

Response	Model variable	RSM	ANN
TP removal (%)	Experimental	91.11	
	Predicted	88.60	89.78
	R <sup>2</sup>	0.9890	0.9894
	MSE	5.135	1.976
	RMSE	2.2661	1.406
TKN removal (%)	Experimental	82.41	
	Predicted	81.90	82.15
	R <sup>2</sup>	0.9869	0.9894
	MSE	5.330	1.389
	RMSE	2.309	0.375
Lipid production (%)	Experimental	20.60	
	Predicted	20.47	20.58
	R <sup>2</sup>	0.9870	0.9979
	MSE	0.333	0.173
	RMSE	0.577	0.781

$$Y_{(TP\ removal)} = 83.89 + (15.46 A) + (1.19 B) + (3.16 C) - (1.40 AB) - (0.20 AC) + (0.73 BC) - (35.18 A^2) - (6.46 B^2) - (1.55 C^2)$$

$$Y_{(TKN\ removal)} = 76.37 + (13.90 A) + (1.75 B) + (1.92 C) - (0.87 AB) + (0.19 AC) + (0.53 BC) - (33.25 A^2) - (6.66 B^2) + (3.61 C^2)$$

$$Y_{(Lipid\ production)} = 19.09 + (3.48 A) + (0.43 B) + (0.48 C) - (0.21 AB) + (0.04 AC) + (0.13 BC) - (8.31 A^2) - (1.66 B^2) + (0.90 C^2)$$

On the other hand, the development of ANN models showed that for TP/TKN and lipid production models, the architect worked efficiently for all three phases i.e., training, testing, and validation. Overall, the  $R^2$  values were above 0.9800 for all the development steps. However, the errors were minimum while using 6, 6, and 5 epochs at gradient levels of 0.4896, 47.0075, and  $< 0.0001$ , respectively for TP/TKN and lipid production models (**Supplementary information 1**). The minimum difference between the experimental and predicted response values was also encountered for ANN models. The comparative assessment of experimental vs. predicted model values in terms of TP/TKN removal and lipid production of *C. vulgaris* is given in Fig. 4. The optimization studies revealed that maximum reduction of TP (90.35%) and TKN (83.55) along with maximum enrichment of lipid contents in *C. vulgaris* (20.88%) can be achieved by adjusting the PIWW concentration at 60.73%, reactor temperature of 25.62°C, and light intensity of 4000 lx, respectively (Table 6).

Table 6  
Optimization results for maximized phycoremediation of pharmaceutical industry wastewater and lipid production using *C. vulgaris*

Variable	Target	Value	Unit
Desirability	-	0.99	
Pharmaceutical wastewater concentration	In-range	60.73	%
Reactor temp.	In-range	25.62	°C
Light intensity	In-range	4000	lx
TP removal	Maximized	90.35	%
TKN removal	Maximized	83.55	%
Lipid production	Maximized	20.88	%

Previous studies have shown that the efficiency of artificial neural network models is much higher as compared to RSM models (Kumar et al. 2021). The same justification was observed from the results of this study also. In a recent study, Liyanaarachchiet al. (2021) constructed RSM and ANN-based models for the optimization of algal biomass, total lipid, unsaturated lipid, and oleic acid production along with time and pH. After 16 days, the optimum oleic acid concentration of 745.21 mg/L was noticed at pH 7.46. On the other hand, 2663.34, 1266.33, and 1072.58 mg/L of algal biomass, total lipid, and unsaturated lipids production was observed, respectively. Since the above studies also support the findings of our study, therefore, both the RSM and ANN models can be effectively used in the optimization of PIWW phycoremediation experiments using isolated *C. vulgaris*.

## 4. Conclusion

This study concluded that the isolated *C. vulgaris* was capable of eliminating the TP (91.11%) and TKN (82.41%) pollutants of PIW wastewater along with significant enrichment of lipid contents (20.60%). Based on the reactor optimization studies, the optimum values of PIWW concentration, temperature, and light intensity were 60.73%, 25.62 °C, and 4000 lx, respectively. RSM and ANN modeling showed that both models can be used for designing and optimizing phycoremediation experiments. However, ANN models were identified as more robust in terms of high accuracy and fewer error parameters as compared to RSM models. Overall, the study suggests that phycoremediation might be a suitable option for the biological treatment of PIWW. Moreover, the harvested algal biomass showed a good amount of lipid content, therefore, it can also be utilized for biofuels production. Further studies on the occurrence of different pharmaceutical compounds such as antibiotics and their effects on algal growth are highly recommended.

## Declarations

### Acknowledgment

The authors are highly grateful to the Department of Zoology and Environmental Sciences, Gurukul Kangri (Deemed to be University), Haridwar, India, and Department of Environmental Sciences, Central University of Jammu (CUJ) for providing the desired laboratory facilities for the experiments.

**Funding:** No funding was received for this study.

**Ethics approval:** This article does not contain any studies with human participants or animals.

**Consent to participate:** All authors mutually agreed to participate in this work.

**Consent for publication:** All authors mutually agreed to publish the work.

**Competing interests:** The authors declare that there are no competing interests.

## References

- AsadiP RadHA QaderiF (2019) Comparison of *Chlorella vulgaris* and *Chlorella sorokiniana* pa. 91 in post treatment of dairy wastewater treatment plant effluents. Environ Sci Pollut Res 26(28):29473–29489. <https://doi.org/10.1007/s11356-019-06051-8>
- AzizA BF, SengarA KhanSU, Farooqi IH (2019) Biological wastewater treatment (anaerobic-aerobic) technologies for safe discharge of treated slaughterhouse and meat processing wastewater. Sci Total Environ 686:681–708. <https://doi.org/10.1016/j.scitotenv.2019.05.295>
- Azizi S, Bayat B, Tayebati H, Hashemi A, Pajoum Shariati F (2020) Nitrate and phosphate removal from treated wastewater by *Chlorella vulgaris* under various light regimes within membrane flat plate photobioreactor. Environ Prog Sustain Energy e13519. <https://doi.org/10.1002/ep.13519>
- BadarSN MohammadM, EmdadiZ, Yaakob Z, Biofuels (2018) <https://doi.org/10.1080/17597269.2018.1472978>
- BambaBSB LozanoP, AdjéF, Ouattara A, VianMA, TranchantC LozanoY (2015) Effects of temperature and other operational parameters on *Chlorella vulgaris* mass cultivation in a simple and low-cost column photobioreactor. 177:89–406. <https://doi.org/10.1007/s12010-015-1751-7>
- BansalA SO, Sarkar S (2018) Industrial wastewater treatment using phycoremediation technologies and co-production of value-added products. J Bioremediat Biodegrad 9(1):1–10. <https://doi.org/10.4172/2155-6199.1000428>

7. BellingerEG, Sigeo DC (2015) Freshwater algae: identification, enumeration and use as bioindicators. John Wiley & Sons. <https://doi.org/10.1002/9781118917152>
8. Beuckels A, Smolders E, Muylaert K (2015) Nitrogen availability influences phosphorus removal in microalgae-based wastewater treatment. *Water Resour* 77:98–106. <https://doi.org/10.1016/j.watres.2015.03.018>
9. Carvalho ACB, Lana TN, PerfeitoJPS, Silveira D (2018) The Brazilian market of herbal medicinal products and the impacts of the new legislation on traditional medicines. *J Ethnopharmacol* 212:29–35. <https://doi.org/10.1016/j.jep.2017.09.040>
10. Chang HX, Huang Y, FuQ,Liao Q ZhuX(2016)Kinetic characteristics and modeling of microalgae *Chlorella vulgaris* growth and CO<sub>2</sub>biofixation considering the coupled effects of light intensity and dissolved inorganic carbon. *BioresourTechnol*206:231–238. <https://doi.org/10.1016/j.biortech.2016.01.087>
11. Cong Q, Yu W (2018) Integrated Soft Sensor with Wavelet Neural Network and Adaptive Weighted Fusion for Water Quality Estimation in Wastewater Treatment Process.*Measurement* 1–22. <https://doi.org/10.1016/j.measurement.2018.01.001>
12. Dar RA, ShahnawazM QaziPH(2017)General overview of medicinal plants: A review. *TheJPhytopharm*6(6):349–351
13. Dixit D, Parmar N (2013) Treatment of pharmaceutical waste water by electro-coagulation and natural coagulation process: review. *VSRD Int J Technol NonTechnol Res* 4(5):79–88
14. DuanZ TanX, Zhang ParajuliKUpadhyayS, Shu D, Liu X Q (2018) Colony formation in two Microcystis morphotypes: Effects of temperature and nutrient availability. *Harmful Algae* 72:14–24. <https://doi.org/10.1016/j.hal.2017.12.006>
15. EggerG BinnsA (2017) RössnerS Health and the Environment: Clinical Implications for Lifestyle Medicine. In *Lifestyle Medicine* (pp. 309–315). Academic Press. <https://doi.org/10.1016/b978-0-12-810401-9.00019-x>
16. EscapaC CoimbraRN, GarcíaAI PaniaguaS OteroM(2017)Comparison of the culture and harvesting of *Chlorella vulgaris* and *Tetrademus obliquus* for the removal of pharmaceuticals from water.*J ApplPhycol*29(3):1179–1193. <https://doi.org/10.1007/s10811-016-1010-5>
17. FaizAA PoonamS, AbhishekG FaizalB (2017) Microalgal cultivation using aquaculture wastewater: integrated biomass generation and nutrient remediation. *Algal Resour* 21:169–161
18. FayyadRJ, MuslimSN, AliANM (2020) Application strategies for using fungi and algae as bioremediators: a review. *Plant Arch* 20(1):788–792
19. Hess SK, Lepetit B, Kroth PG, Mecking S (2018) Production of chemicals from microalgae lipids–status and perspectives. *Eur J Lipid Sci Technol* 120:1700152. <https://doi.org/10.1002/ejlt.201700152>
20. JayaswalK,Sahu V GurjarBR(2018)Water pollution, human health and remediation. In *Water Remediation* (pp.11–27).Springer, Singapore, [https://doi.org/10.1007/978-981-10-7551-3\\_2](https://doi.org/10.1007/978-981-10-7551-3_2)
21. KarpagamR JawaharK, Ashok kumar B VaralakshmiP(2015)Characterization and fatty acid profiling in two fresh water microalgae for biodiesel production: lipid enhancement methods and media optimization using response surface methodology. *BioresourTechnol*188:177–184. <https://doi.org/10.1016/j.biortech.2015.01.053>
22. Kumar P, KumarV, Singh J KumarP(2021)Electrokinetic assisted anaerobic digestion of spent mushroom substrate supplemented with sugar mill wastewater for enhanced biogas production.*Renew Energy*179:418–426. <https://doi.org/10.1016/j.renene.2021.07.045>
23. KimZ ShinY, YuJ KimG, HwangS (2019) Development of NO<sub>x</sub> removal process for LNG evaporation system: Comparative assessment between response surface methodology (RSM) and artificial neural network (ANN). *J IndEng Chem* 74:136–147
24. LeeH,JeongD ImS, Jang A (2020) Optimization of alginate bead size immobilized with *Chlorella vulgaris* and *Chlamydomonas reinhardtii*for nutrient removal. <https://doi.org/10.1016/j.biortech.2020.122891>. *BioresourTechnol*302: 122891
25. LiyanaarachchiVC NishshankaGKSH, SakarikaM,NimarshanaPHV, Ariyadasa TU, Komaros M(2021)Artificial neural network (ANN) approach to optimize cultivation conditions of microalga *Chlorella vulgaris* in view of biodiesel production.*BiochemEngJ*172:1–10<https://doi.org/10.1016/j.bej.2021.108072>
26. López G, Yate C, Ramos FA, Cala MP, Restrepo S, Baena S (2019) Production of polyunsaturated fatty acids and lipids from autotrophic, mixotrophic and heterotrophic cultivation of *Galdieria* sp. strain USBA-GBX-832. *Sci Rep* 9:1–13. <https://doi.org/10.1038/s41598-019-46645-3>
27. MadadiR ZahedMA, PourbabaeeAA TabatabaeiM (2021) Simultaneous phycoremediation of petrochemical wastewater and lipid production by *Chlorella vulgaris*. *SN Appl Sci* 3(4):1–10. <https://doi.org/10.1007/s42452-021-04511-w>
28. MaityS SinghaK PanditP(2021)Textile wastewater management. In *Green Chemistry for Sustainable Textiles* (pp.417–427).Woodhead Publishing
29. Mao G, Shi K, Zhang C, Li J, Chen S, Wang P (2020) Biodiesel Fuel from *Chlorella vulgaris* and Effects of Its Low-Level Blends on the Performance, Emissions, and Combustion Characteristics of a Nonroad Diesel Engine. *J Energy Eng* 146:4020016. [https://doi.org/10.1061/\(asce\)ey.1943-7897.0000668](https://doi.org/10.1061/(asce)ey.1943-7897.0000668)
30. Martínez-PachónD Echeverry-GallegoRA, HernándezF Serna-GalvisEAVillarrealJMBotero-CoyAM, Moncayo-LassoA (2021) Treatment of wastewater effluents from Bogotá–Colombia by the photo-electro-Fenton process: Elimination of bacteria and pharmaceutical. *Sci Total Environ* 772:144890. <https://doi.org/10.1016/j.scitotenv.2020.144890>
31. MetsovitiMN, Papapolymerou G, Karapanagiotidis IT KatsoulasN(2020)Effect of light intensity and quality on growth rate and composition of *Chlorella vulgaris*. *Plants*9(1):31. <https://doi.org/10.3390/plants9010031>
32. Miao MS, Yao XD, ShuL, YanYJ, WangZLiN KongQ (2016) Mixotrophic growth and biochemical analysis of *Chlorella vulgaris* cultivated with synthetic domestic wastewater. *Int Biodeterior Biodegradation* 113:120–125. <https://doi.org/10.1016/j.ibiod.2016.04.005>

33. Nayak JK, Ghosh UK (2019) Post treatment of microalgae treated pharmaceutical wastewater in photosynthetic microbial fuel cell (PMFC) and biodiesel production. *Biomass Bioenergy* 131:105415. <https://doi.org/10.1016/j.biombioe.2019.105415>
34. Pal P (2018) Treatment and disposal of pharmaceutical wastewater: toward the sustainable strategy. 47:179–198. <https://doi.org/10.1080/15422119.2017.1354888>. 3
35. PatilS (2016) Early access programs: Benefits, challenges, and key considerations for successful implementation. *Perspect Clin Res* 7(1):4. <https://doi.org/10.4103/2229-3485.173779>
36. PudasainiN UpadhyayPP, ParkerCR, HagenSU, BondAD,Rantanen J (2017) Downstream processability of crystal habit-modified active pharmaceutical ingredient. *Org Process Res Dev* 21(4):571–577. <https://doi.org/10.1021/acs.oprd.6b00434>
37. RanaRS, Singh P, KandariV SinghR, Gupta DobhalR S (2017) )A review on characterization and bioremediation of pharmaceutical industries' wastewater.. an Indian perspective *Appl Water Sci* 7(1):1–12. <https://doi.org/10.1007/s13201-014-0225-3>
38. SabourMR AmiriA (2017) Comparative study of ANN and RSM for simultaneous optimization of multiple targets in Fenton treatment of landfill leachate. *Waste Manag* 65:54–62. <https://doi.org/10.1016/j.wasman.2017.03.048>
39. SboichakovVB ReshetnikovaOV(2020)Microbial degradation of wastewater.LimnolFreshwBiol1021-1022
40. ShahA ShahM (2020) Characterisation and bioremediation of wastewater: a review exploring bioremediation as a sustainable technique for pharmaceutical wastewater. *Groundw Sustain Dev* 11:100383. <https://doi.org/10.1016/j.gsd.2020.100383>
41. SharmaJ KumarV, Malyan KumarSS, MathimaniT SK, BishnoiNR,PugazhendhiA (2020) Microalgal consortia for municipal wastewater treatment– Lipid augmentation and fatty acid profiling for biodiesel production. *J PhotochemPhotobiol B Biol* 202:111638. <https://doi.org/10.1016/j.jphotobiol.2019.111638>
42. ShresthaP ShresthaR DangolB(2017)Status of wastewater generation and management in urban Nepal.*J Environ*1(1):1–6
43. Singh R, BirruR SibiG(2017)Nutrient removal efficiencies of *Chlorella vulgaris* from urban wastewater for reduced eutrophication.*Journal of Environmental Protection*8(01):1, <https://doi.org/10.4236/jep.2017.81001>
44. SeragadamP RaiA, Ghanta KC, SrinivasB, LahiriSK DuttaS(2021)Bioremediation of hexavalent chromium from wastewater using bacteria-a green technology. *Biodegradation* 1–18. <https://doi.org/10.1007/s10532-021-09947-w>
45. SubashiniPS, Rajiv P (2018) An investigation of textile wastewater treatment using *Chlorella vulgaris*. *OrientJ Chem* 34(5):2517. <https://doi.org/10.13005/ojc/340538>
46. SydneyEB, Sydney ACN, de CarvalhoJC,Soccol CR(2019)Potential carbon fixation of industrially important microalgae. *Biofuels from Algae* pp.67–88. <https://doi.org/10.1016/b978-0-444-64192-2.00004-4>
47. TalaveraG, Castresana J (2007) Improvement of phylogenies after removing divergent and ambiguously aligned blocks from protein sequence alignments. *SystBiol*. 56:564–577. <https://doi.org/10.1080/10635150701472164>. 4
48. XiongJQ KuradeMB, JeonBH (2017) Biodegradation of levofloxacin by an acclimated freshwater alga *Chlorella vulgaris*. *Chem Eng J* 313:1251–1257. <https://doi.org/10.1016/j.cej.2016.11.017>
49. ZhangC HuangJ(2015)Optimization of process parameters for pharmaceutical wastewater treatment.*Pol J Environ Stud*24(1):391–395. <https://doi.org/10.15244/pjoes/27866>
50. ZhangQ LiuYP, LuoFL DongBC YuFH(2019)Does species richness affect the growth and water quality of submerged macrophyte assemblages? *Aquatic botany* 153:51–57. <https://doi.org/10.1016/j.aquabot.2018.11.006>
51. ZhuL HuT, LiS NugrohoYK, Cao LiB, Hiltunen J E (2020) Effects of operating parameters on algae *Chlorella vulgaris* biomass harvesting and lipid extraction using metal sulphates as flocculants. *Biomass Bioenergy* 132:105433. <https://doi.org/10.1016/j.biombioe.2019.105433>
52. ZnadH A, Ketife AM, JuddS, AIMomaniF VuthaluruHB(2018)Bioremediation and nutrient removal from wastewater by *Chlorella vulgaris*.*EcolEng*110:1–7

## Figures

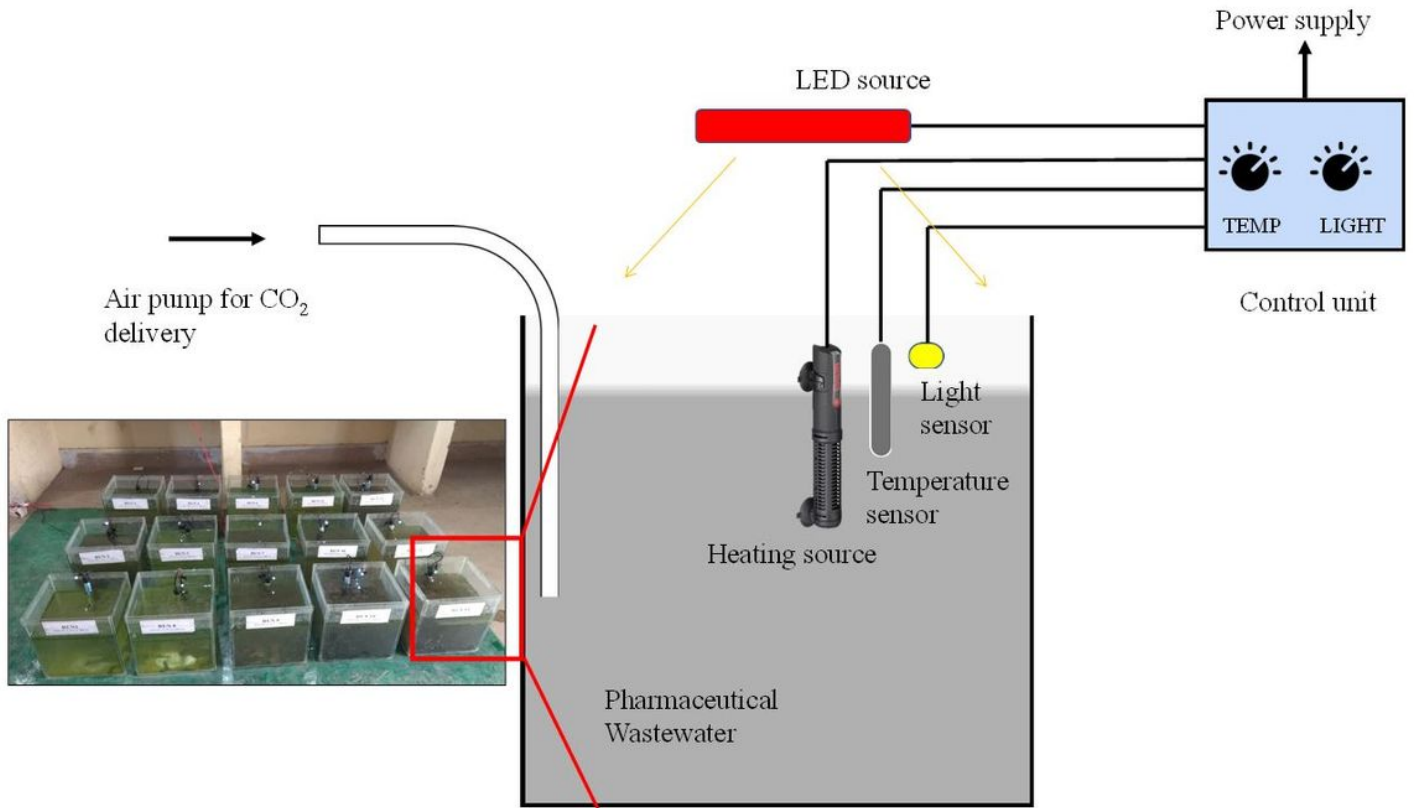

Figure 1

Design of the reactor used for algal cultivation.

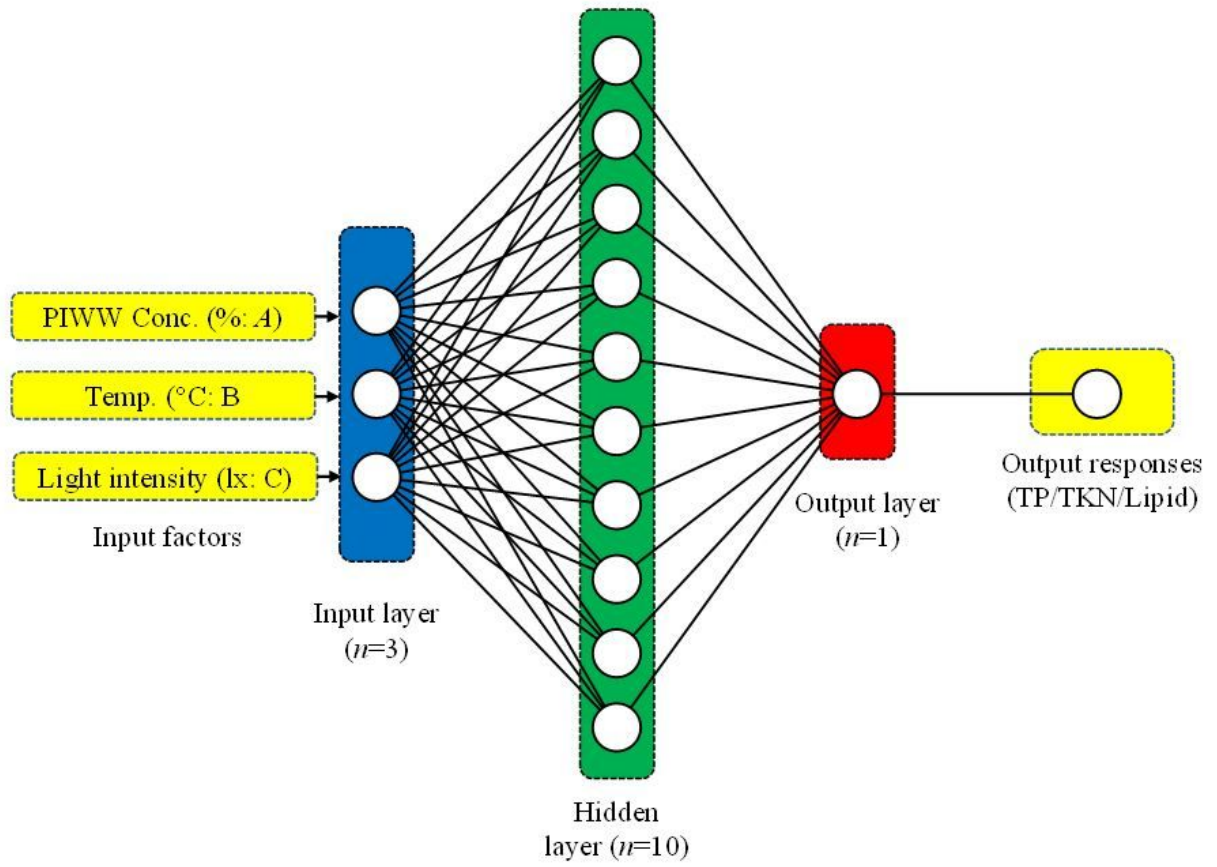
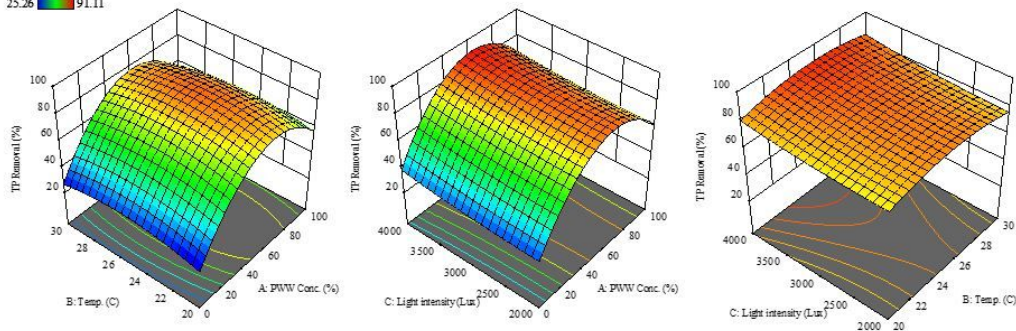

Figure 2

Configuration of the ANN with different numbers of layers and neurons.

Factor Coding: Actual  
25.26 91.11



Factor Coding: Actual  
23.55 82.41

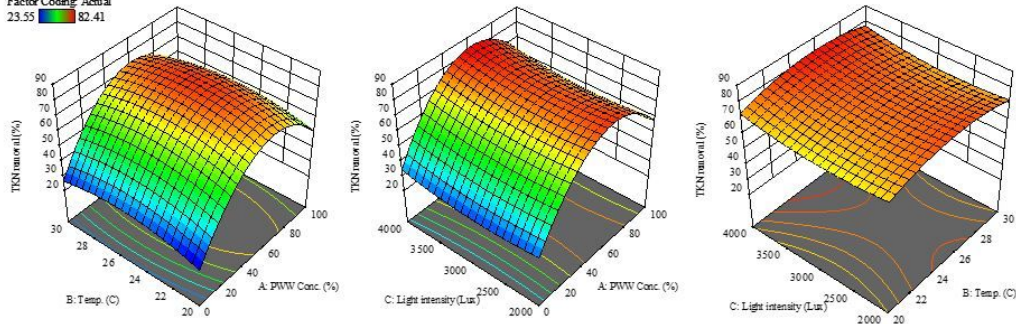

Factor Coding: Actual  
5.88 20.6

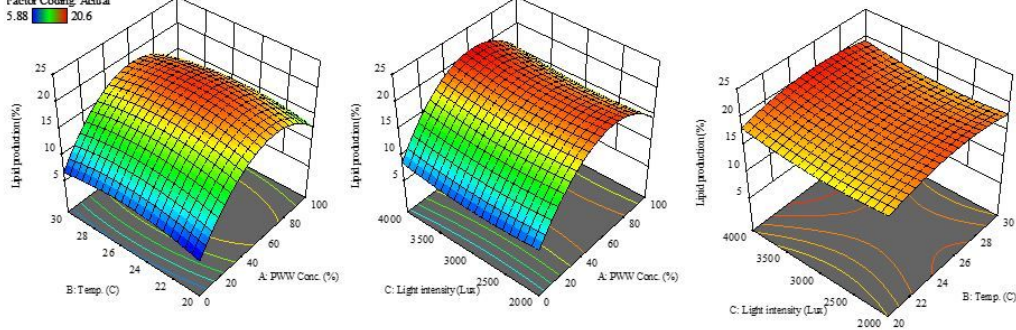

Figure 3

3D-surface plot for interactive effects of PWW concentration, temperature, and light intensity on TP/TKN removal and lipid production by *C. vulgaris*.

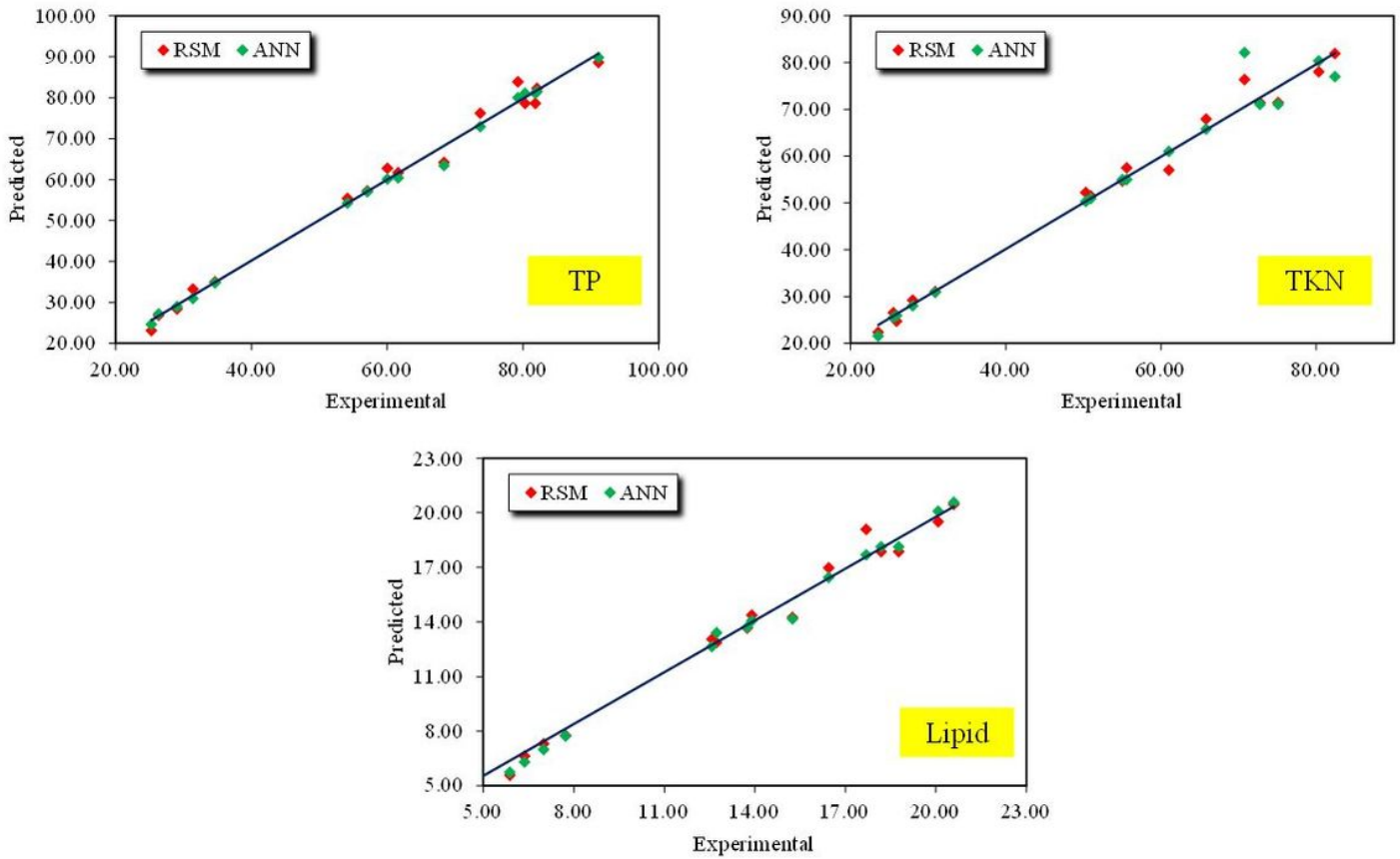

Figure 4

Comparative feasibility of RSM and ANN models in predicting total phosphorus, total Kjeldahl's nitrogen, and lipid production of *Chlorella* sp.

## Supplementary Files

This is a list of supplementary files associated with this preprint. Click to download.

- [Supplimentarydata1.docx](#)