

Implementation of Resource Allocation Technique for DVB-RCS Compliant Satellite Terminals in Test-bed Scenario

Abhishek Kumar Roy (✉ abhishekroy@deal.drdo.in)

Defence Electronics Application Laboratory

Rajneesh Singhal

Defence Electronics Application Laboratory

Trilok K. Saini

Defence Electronics Application Laboratory

Satyendra Kumar

Defence Electronics Application Laboratory

Manoj K. Dhaka

Defence Electronics Application Laboratory

Research Article

Keywords: Satellite Communication, DVB-RCS, Resource Allocation

Posted Date: December 6th, 2022

DOI: <https://doi.org/10.21203/rs.3.rs-2329010/v1>

License:   This work is licensed under a Creative Commons Attribution 4.0 International License.

[Read Full License](#)

Additional Declarations: No competing interests reported.

Implementation of Resource Allocation Technique for DVB-RCS Compliant Satellite Terminals in Test-bed Scenario

Abhishek Kumar Roy, Rajneesh Singhal, Dr. Trilok K. Saini, Satyendra Kumar, Manoj K. Dhaka
Defence Electronics and Applications Laboratory (DEAL), Dehradun
abhishekroy@deal.drdo.in

Abstract: Satellite communication is advantageous for several reasons such as broad coverage, small installation time of remote user sites, and network services in inhospitable terrains, where installing terrestrial infrastructure is costly. With the advent of broadband multimedia satellites such as Ku and Ka band satellites, multimedia services to the satellite terminals are gaining momentum. Digital Video Broadcast Return Channel via Satellite (DVB-RCS) is an open standard developed by ETSI which has further standardized, commercialized and solved the problem of inter-operability of Ku Band satellite terminals. Satellite bandwidth is scarce therefore treated as precious resource. In the present paper, authors aim to develop and realize the resource allocation techniques in return link channel for DVB-RCS compliant satellite terminals. The paper provides method for giving preference to real time application in terms of early processing of allocation request generated against the real time traffic to reduce delay and also provides method to avoid parallel connection arises due to transmission of terminal on more than one frequency at a time. Authors have realised DVB-RCS resource allocation technique and have given simulation results.

Index Terms—Satellite Communication, DVB-RCS, Resource Allocation

I. INTRODUCTION

Digital Video Broadcasting –Return Channel via Satellite (DVB -RCS) is an open standard developed by ETSI (European Telecommunication Standard Institute). This standard provides specification for multimedia satellite communication. The traditional solutions for multimedia applications over satellite using VSATs (Very Small Aperture Terminals) were specific to vendors were not inter-operable with the solutions provided by the other vendors [1] [10]. In order to combat the problem of inter-operability and to harness the advantage of economy of scale this open standard came into existence. This standard gave major push to the commercialization of DVB-RCS compliant system besides cost reduction. This standard is developed by industry association of more than 200 companies having expertise in satellite domain. However, this standard leveraged the technology used in Digital video broadcasting to achieve high-speed IP multimedia communication over satellite and Internet access over satellite. DVB-RCS, and particularly its successor standard DVB-RCS2 supports two-way satellite communications with upload (Tx) speed up to 75 Mbps and download (Rx) speed up to 150 Mbps provided that sufficient transponder capacity are provided [7] [14].

Before DVB-RCS standard is developed VSATs having two way capabilities were expensive and data rate was limited up to 500 Kbps. DVB-RCS uses either DVB-S or DVB-S2 for Forward link in a TDM/TDMA network. DVB standards are recognized by many governmental and commercial organizations around the world, as open, international, well documented technical standards that encourage industry-wide adoption and the long-term viability. This is key for the advancement of the next generations of large scale, high throughput digital satellite networks serving both public and private communications around the world. DVB-RCS standard provides details about burst wave forms (burst size, structure, modulation type FEC methods) for networks using dynamic MF-TDMA. It clearly brings out the detail of TDMA synchronization methods, the IP encapsulation protocols, and other required control signalling messages for return link operation. In forward link Service

Information (SI) is sent for TDMA operation. TDM carrier is to be compatible to both MPEG digital TV programming and interactive data services [6]. The use of MPEG-TS (transport streams) multiplexes both type of streams with the use of Multiple Protocol Encapsulation (MPE) for IP packets. DVB-RCS is a mature open source satellite communication standard for efficiently utilize the bandwidth management. This paper is organised as follows.

Section II details the survey of important work related to technique of resource allocation of DVB-RCS standard.

Section III introduces the problem definition of resource allocation and presents software architecture to solve the problem. Besides, it also describes tables of TDM and log on procedure of the terminal.

Section IV delves upon nuance of priority of capacity categories in resource allocation, algorithm for priority scheduler, resource allocation constraints, algorithm of finding appropriate slot(s) and procedure for resource deallocation.

Section V details test setup, implementation results.

Section VI details conclusion.

II. RELATED WORKS

Various publications have presented different approaches to develop DVB-RCS system. In [1] authors propose novel method of dynamic allocation and quality-of-service aspects of DVB-RCS system. They have validated their results with the special purpose advanced Internet network emulator. This paper also provides an algorithm for dynamically computing the capacity request at RCST according to the status of queue. While assigning, it assigns first RT request class, then CD request class and BE request class. However, paper doesn't discuss at what time CRA request is sent and how QoS is maintained for different request classes.

In [2], authors discuss the method of bandwidth allocation by taking information from physical (PHY) layer information (the spectral efficiency of each DVB-RCS terminal) and from the upper layers the information about quality of service (QoS) of every traffic flow thus making it cross-layer DBA problem. It also proposes that if terminal is allowed to transmit in any slot (arbitrary bandwidth and time duration) as no structure or constraint is imposed which is simple and principally good design. In this case searching of an appropriate slot would take exponential time (making it NP-hard) due to combinatorial number of possibilities.

In [3], paper presents details of complete DVB-RCS system, developed as Nera SatLink system. NCC is responsible for synchronization of the system, via the network clock reference (NCR), and transmits SI tables for reception and transmission in the system. NCC transmits terminal burst time plan (TBTP) which contains one or more entries of assignments comprising of frequency and timeslots. Besides other fields, assignment contains start timeslot and a repetition factor for consecutive timeslot allocations. This paper also provides methods for the construction of frame/super-frame. In a super-frame wherein each frame structure should consist of certain number of CSC, SYNC, and TRF slots, and that the symbol and FEC rates of each channel may differ. There could be another option for construction of frames having CSC on one channel and SYNC on other channel.

For Bandwidth optimization with frequency hopping terminals should be allocated slots from the channel having stronger coding (e.g. $\frac{1}{2}$, $\frac{2}{3}$ etc.) and lower symbol rate, if transmission condition at terminal side suddenly degrades due to rain. However, condition of link should be gauged at NCC to counter link degradation that can be done by surveying each terminal in terms of signal-to-noise ratio and error rate. Terminal is required to switch from one frequency to another for capacity optimization by harnessing adaptive FEC, and symbol rate. In of one of the artefact, return link is composed of four

return link carriers, out of them three have a FEC rate of 6/7, and one 1/2. In normal conditions, the terminals will be allocated capacity in the three channels with the weakest code protection, i.e., the FEC rate is 6/7. In the period of disturbances, the affected terminal(s) may be allocated slots in the channel with the lower code rate (stronger code). When the conditions return to normal, the terminal(s) will be allocated slots in the channels with a higher coding rate again.

However, when the terminal is switched to better protected channel, the service will continue without interruption, but if no extra slots are allocated to compensate the data rate, the terminal will experience a lower user data rate which is normally better than an interrupted service.

In [4], paper proposes, a novel Hybrid Bin-packing algorithm for maximum utilization of the multi-frequency time division multiple access frame. It assumes frame duration to be fixed at 26.5ms The SF shall have dynamic structure having variable number of frames in a row. Firstly, the NCC collects all the requests and determines at what instants TBTP is to be sent to the RCSTs, preferably at the beginning of SF secondly the timeslots assigned to each RCST per frame. In the resource assignment problem for MF-TDMA uplinks, the weights are the bursts of timeslots requested by each RCST and the bins are the carriers that all contain T timeslots. While accommodating all the bursts provided that number of unused timeslots are minimized. The problem is to accommodate all the bursts onto the carriers minimizing the number of unused timeslots. In this context, a novel Hybrid Bin-packing Algorithm is proposed.

However, this will not be the case always that allocation would be in burst. This paper doesn't discuss how to avoid parallel transmission. It treats real time and non-real time traffic alike.

In [5], paper compares the predictive allocation with fixed allocation or the requests based on current size of terminals' queue in case of non bursty traffic, a fixed allocation performs better than the predictive technique as it involves lesser exchange of signalling messages. However, this paper, doesn't discuss actual scheduling of the slots or the exact position of the allocated slots in the frame.

In [6], authors have developed limited version prototype of DVB-RCS is implemented and is tested using single RCST. It implements forward link and return link with the COTS items on the HUB. It has implemented one super-frame with one frame and a single carrier in return this make capacity request and assignment lot easier. This solution uses limited features of DVB-RCS standard such as Constant Rate Assignment (CRA) and MPEG option only, thus wastes lot of precious bandwidth as terminals may not be using this all the time.

In this paper, we provide methods for giving preferences to real time data over non-real time data and reduce the delay of processing of real time request required for real time multimedia services like voice/video.

The earlier papers don't address how to prevent parallel transmission. This paper provides method to invalidate the overlapping slots by formulating forbidden zone.

Forbidden zone further imposes structural constraints on Frequency time grid that minimizes the search space for prospective slots, otherwise searching an appropriate slot would take exponential time making it NP hard had there been every slot having choice of being selected or rejected, i.e. for n slots there are 2^n choices.

III. DVB-RCS RESOURCE ALLOCATION PROBLEM: DEFINITION AND PROPOSED APPROACH

A. Resource Allocation Scenario

The typical deployment scenario is depicted in Fig. 1 comprises of Return Channel Satellite Terminal (RCST), Ku Band satellite and HUB. HUB contains Network Control Centre (NCC) that essentially authenticates terminals, allocates resources for synchronization of terminals and forwarding of traffic, and maintains synchronization procedure in addition to providing other networking functionalities. HUB acts as a Gateway to other type of network such as PSTN etc. It uses DVB-S2 in forward link and DVB-RCS in the return link.

Satellite return link channels have limited bandwidth thus makes it precious resource [15] [16]. Many RCSTs compete for resources, as shown in Figure 1, therefore, efficient allocation makes of resources is imperative in order to make efficient utilization of network bandwidth. Static allocation of resources wastes lot of bandwidth as all the terminals are not active all the time. In the bursty nature of traffic Demand Assigned Multiple Access (DAMA) is suitable candidate for achieving bandwidth efficiency.

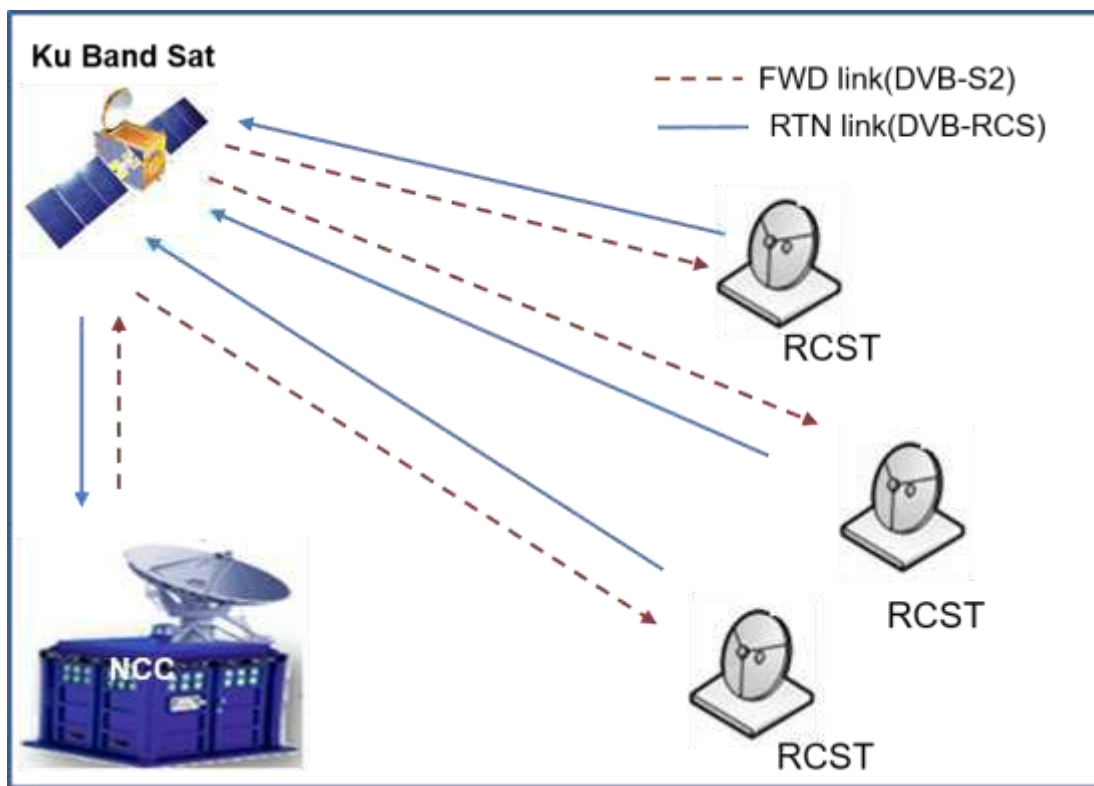

Fig. 1. RCSTs competing for resources.

B. Software architecture

There shall be two modules DAMA agent that sits on RCST and DAMA Controller that sits on NCC. DAMA agent shall behave like terminal i.e. it sends the log on and capacity request packet and NCC shall send log on reply and allocate resources as depicted in Fig. 2. In actual scenario, DAMA agent transmits data on satellite link but in present implementation both the modules are connected though UDP socket.

RCST inter alia contains DAMA agent. DAMA agent has following modules

- **Log On Handler**

To enter into network RCST wait for CSC slots then it transmits the log on request in prescribed format (SAC), NCC generates log on reply packet (TIM-U). If TIM-U packet is not received in prescribed time it again sends the log on request if maximum retry has not been reached.

- **Traffic Classifier**

This module would classify the incoming traffic in different request classes such as voice, video, web browsing data based on the QoS requirement. However, in present implementation traffic classification is done with the predefined value.

- **Capacity Evaluator**

This module evaluates how much resource is required by RCST in various capacity categories such as CRA, VDBC, RBDC, etc. based on the data in the various queues. Amount of resource requested is depend upon many factors such as incoming data rate, how much resources are requested. Detailed algorithm for capacity evaluation is explained in [1].

- **Request Manager**

This module transmits capacity request (CR) in prescribed format as detailed in [11]. It makes use of evaluated capacity calculated by capacity evaluator. An RCST use more than one RC, each identified by an RC identifier (RC_INDEX). This RC_INDEX is included in the CR message sent to the NCC. On reception of a CR, the NCC allocates resources, based on the information associated with the RC per RCST, such as relative priority of the CR or limits on resource usage, NCC allocates time slots by sending TBTP.

NCC inter alia contains DAMA controller. DAMA controller has following modules

- **Log On reply handler**

This module stores in coming log on request packet and prepares log on reply packet in appropriate format (TIM-U) as described in the DVB-RCS standard and transmit to RCST. It assigns log on ID against MAC ID which is valid till the RCST is logged out and also assigns CRA and Synchronization resources (ACQ and SYNC slots). It also maintains the active list of RCST which are currently logged on.

- **Capacity request scheduler**

It creates the list of logged on terminals along with the capacity request per RC_INDEX. It receives capacity request packet sent by RCSTs and update the list. It calculates the total demand by any RCST and by each RC_INDEX of that terminal. If request is served for any terminal it removes that terminals from that list.

- **Resource allocation**

This module is the heart of the software as this is entrusted for slot allocation for synchronization as well as traffic. This module is explained in great length in section IV. This module also generates important tables of TDM such as SCT, FCT and TCT.

- **TBTP Generator**

This module generates TBTP for allocated timeslots and sends to RCST. RCST in turn sends traffic into the allocated slots. This module sends info only when there is any allocation to be sent.

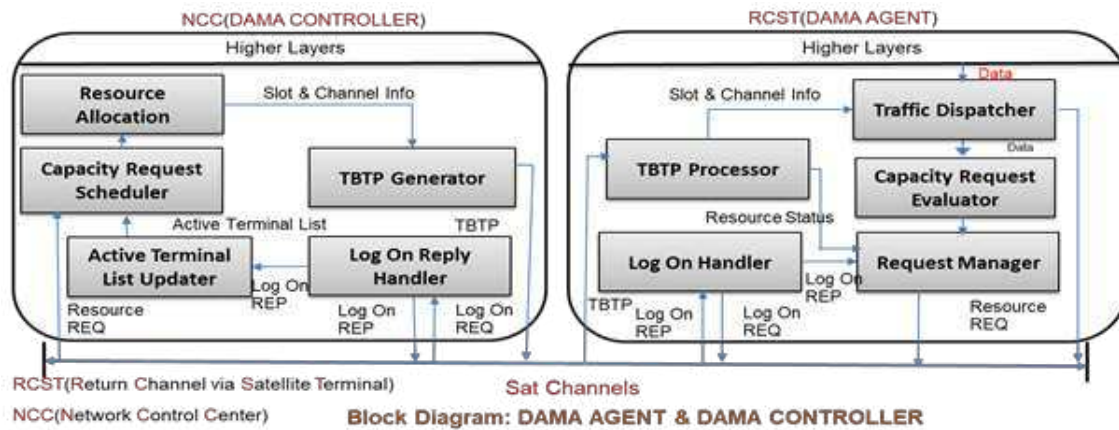

Fig. 2. Software architecture for realization of resource allocation method.

C. TDM Generation

Once any RCST is powered on it has to acquire control parameters for log on and synchronization and structure of bandwidth in return link. However, synchronization procedure is out of the scope.

Control parameters are sent in two descriptors i.e., contention control descriptor and correction control descriptor. Contention control descriptor contains retransmission parameters for CSC bursts such as CSC response timeout, CSC Max losses, Max time before retry, whereas correction control descriptor contains timeouts for coarse synchronization, fine synchronization, and synchronization maintenance procedure. These descriptors are periodically broadcasted with periodicity of 5 seconds, so that any RCST can enter into the network.

The bandwidth capacity of return link is described by Super-frame Composition Table (SCT), Frame Composition Table (FCT) and Timeslot Composition Table (TCT). These tables are also broadcasted with periodicity of 10 seconds so that any change in the structure of bandwidth segmentation can be conveyed to RCST. Once RCST has acquired TDM then only it can send long on request (CSC burst) and resource request (SYNC burst).

Terminal Bust Time Plan forms the part of TDM, is sent only when there exists any allocation. Composition of SCT, FCT and TCT has not been discussed in the standard. It has been left to the implementers. In the present implementation, composition of SCT, FCT and TCT are as follows

a. Timeslot Composition Table (TCT)

TCT provides information about the parameters of slots such as symbol rate, modulation, coding rate, etc. of different types of time slots available in return link. TCT only describes timeslot properties; frequency and time of a particular timeslot are given in FCT.

In present implementation, four basic types of slots are available; CSC, ACQ, SYNC, and MPEG-TRF. The permutation and combination of different symbol rate, modulation and coding can form different types of time slots. Each type of slot is uniquely identified by the timeslot_id.

In present case, three types of carriers (C1, C2, C3) having different symbol rates are available, that makes 12 types of timeslots in total, keeping modulation and coding fixed. Many types of slots shall be formed if modulation and coding vary.

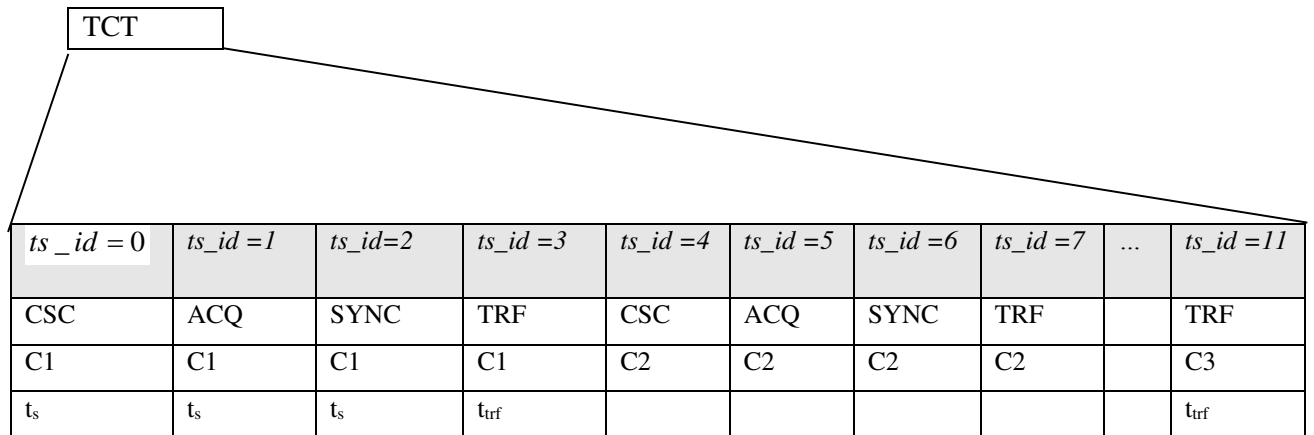

Fig. 3. Composition of TCT

SYNC slots may further be divided such as; SYNC with SAC request, SYNC with M&C by toggling respective flags (M_and_C_Flag).

b. Frame Composition Table (FCT)

FCT provides information related to frame types available in the return link. Frame is particular arrangement of timeslots in frequency and time domain. $frame_id$ uniquely identifies a frame type. In present implementation, there shall be four identical frames within a super-frame and $frame_id = \{0, 1, 2, 3\}$. The value of $frame_id_loop_count = 4$ and $frame_duration = 46ms$.

Table I
COMPOSITION OF FCT

Sl. No.	Carrier Type	Coding	Total Slots(Signaling, Traffic)	Total Channels	Total Slots
1.	C1	1/2	(7,7)	8	14x8=112
2.	C2	1/2	(7,31)	6	38x6=228
3.	C3	1/2	(7,63)	2	70x2=140
	Total Timeslots				480

Every frame starts with $start_slot_no = 0$, and if $no_of_channel = 16$ and $types_of_slot = 12$ then $timeslot_loop_count = no_of_channel \times types_of_slot = 192$.

The composition of channel 1 to 8 of carrier 'C1' shall be same. Example of frame composition table of carrier type 'C1' is shown in Table II

Table II
EXAMPLE OF FCT OF CARRIER TYPE 'C1'

CSC	ACQ	SYNC	TRF
$timeslot_id=0$	$timeslot_id=1$	$timeslot_id=2$	$timeslot_id=3$
$ts_freq_offset=0$	$ts_freq_offset=0$	$ts_freq_offset_offset=0$	$ts_freq_offset_offset=0$

$timeslot_time_offset=0$	$timeslot_time_offset=(repeat_count+1)\times t_{sig}$	$timeslot_time_offset=(repeat_count+1)\times t_{sig}$	$timeslot_time_offset=(repeat_count+1)\times t_{sig}$
$repeat_count=1$	$repeat_count=0$	$repeat_count=3$	$repeat_count=6$

The composition of channel 1 to 6 of carrier ‘C2’ shall be same. Example of frame composition table of carrier type ‘C2’ is shown in Table III.

Table III
EXAMPLE OF FCT OF CARRIER TYPE ‘C2’

CSC	ACQ	SYNC	TRF
$timeslot_id=4$	$timeslot_id=5$	$timeslot_id=6$	$timeslot_id=7$
$ts_freq_offset=0$	$ts_freq_offset=0$	$ts_freq_offset_offset=0$	$ts_freq_offset_offset=0$
$timeslot_time_offset=0$	$timeslot_time_offset=(repeat_count+1)\times t_{sig}$	$timeslot_time_offset=(repeat_count+1)\times t_{sig}$	$timeslot_time_offset=(repeat_count+1)\times t_{sig}$
$repeat_count=1$	$repeat_count=0$	$repeat_count=3$	$repeat_count=30$

The composition of channel 1 to 2 of carrier ‘C3’ shall be same. Example of frame composition table of carrier type ‘C3’ is shown in Table IV.

Table IV
EXAMPLE OF FCT OF CARRIER TYPE ‘C3’

CSC	ACQ	SYNC	TRF
$timeslot_id=8$	$timeslot_id=9$	$timeslot_id=10$	$timeslot_id=11$
$ts_freq_offset=0$	$ts_freq_offset=0$	$ts_freq_offset_offset=0$	$ts_freq_offset_offset=0$
$timeslot_time_offset=0$	$timeslot_time_offset=(repeat_count+1)\times t_{sig}$	$timeslot_time_offset=(repeat_count+1)\times t_{sig}$	$timeslot_time_offset=(repeat_count+1)\times t_{sig}$
$repeat_count=1$	$repeat_count=0$	$repeat_count=3$	$repeat_count=62$

c. Super-frame Composition Table(SCT)

A super-frame defines time and frequency aspect of the return link bandwidth. In present implementation return link capacity is not segmented into multiple segments, therefore only one *superframe_ID* exists. Superframe in time is labelled with a number called "*superframe_counter*".

Resources are allocated in particular *superframe_ID* and *superframe_counter* which are communicated to RCSTs via the TBTP.

d. Log On Procedure

Once RCST has received all SI (Signalling Information) tables related to the structure of satellite network, it is ready to enter into the network and be ready to handle traffic. The RCST sends a logon request containing MAC address and capabilities of terminal in a CSC timeslot available in every channel using Slotted-Aloha random access, as shown in Fig. 4.

The NCC verifies that transmission resources (ACQ and SYNC bursts) and traffic resources for CRA are available and checks if the administrative aspects are satisfied (e.g. account is valid, terminal is registered, etc.). If all conditions are met, the NCC sends a TIM message to the RCST as an acknowledgement. This "logon" TIM shall contain following descriptors [11].

- Correction_message_descriptor
- Logon_initialize_descriptor
- ACQ_assign_descriptor
- SYNC_assign_descriptor
- Contention_control_descriptor
- Correction_control_descriptor
- Return Interaction Path descriptor

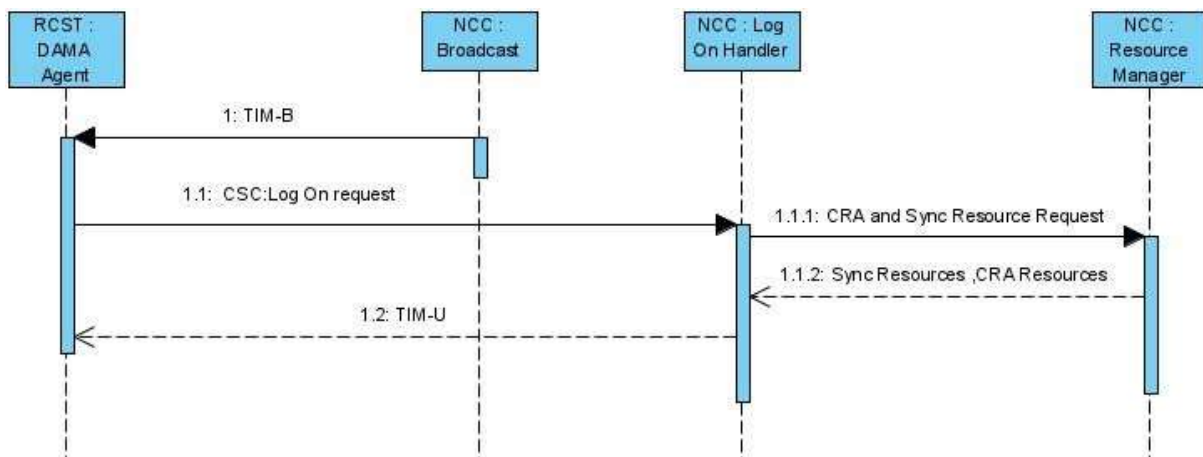

Fig. 4. Sequence diagram of Log On procedure.

IV. DVB-RCS RESOURCE ALLOCATION TECHNIQUE

Return link slot allocation is quite challenging task due to many factors such as MF-TDMA, various DAMA capacity categories such as CRA, RBDC, VBDC and FCA and combination of these, capacity request evaluation algorithm at RCST. However, request evaluation algorithm is out of the scope of the paper.

Capacity request scheduler schedules the incoming capacity request based on the priority and gives to Resource allocation module.

A. Priority in allocation

- a) Processing of request for allocation at HUB shall be done based on the priority of CC ($P_{CRA} > P_{RBDC} > P_{VBDC}$) as a result priority is given to real time traffic over non real time traffic.
- b) Scheduler would de-queue the packet based on the priority of queues (RT > EF > BE). Packets of EF wouldn't be de-queued until RT becomes empty
- c) The upper limit cap is imposed on real time resource request.

Table V
SUMMARY OF REQUEST CLASSES AND CAPACITY CATEGORY

Request Class	Application	Data Rate	Type of service	Resource Allocation method
A	Voice-based(VoIP)	64 kbps(Phone)	Highly sensitive (some hundred ms)	CRA
B	Video Broadcasting	384 kbps(video phone)		RBDC
C	Web Browsing, Email	256 kbps	loosely sensitive (1 sec)	VBDC
D	File transfer	1024 kbps	loosely sensitive (some sec)	VBDC

Packets of EF wouldn't be de-queued until RT becomes empty. While de-queuing EF, if any packet is queued into the RT then scheduler must de-queue the packets from RT once the processing of current packet from EF is finished. In other words, CRA request shall have higher priority than RBDC and VBDC. Mapping of request classes and capacity categories are shown in Table V.

Block diagram of Priority Queue Scheduling is shown in Fig. 5.

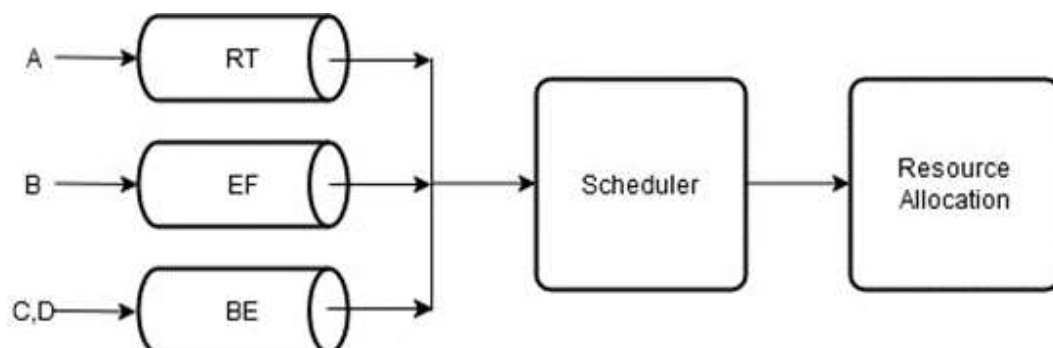

Fig.5.Block diagram of Priority Queue Scheduling.

Algorithm for priority scheduler is shown below.

Priority Scheduler Algorithm

1. *Input: $Q_{CRA}, Q_{RBDC}, Q_{VBDC}$*
2. *Output: Frequency Time Grid*
3. **while**(forever)
4. *unique_lock < mutex > lck(mtx)*
5. **while** (*isEmptyQ(Q_{CRA}) & isEmptyQ(Q_{RBDC}) & isEmptyQ(Q_{VBDC})*)
6. *cv.wait(lck);*
7. **while** (*!isEmptyQ(Q_{CRA})*) # *Processing of CRA queue*
8. **if** (*AllocateResource(& Q_{CRA} .front()) == successful*)
9. *Q_{CRA} .pop();*
10. **while** (*!isEmptyQ(Q_{RBDC})*) # *Processing of RBDC queue*
11. **if** (*AllocateResource(& Q_{RBDC} .front()) == successful*)
12. *Q_{RBDC} .pop();*
13. **if** (*!isEmptyQ(Q_{CRA})*)
14. *break; # process CRA queue*
15. **while** (*!isEmptyQ(Q_{VBDC})*)
16. **if** (*AllocateResource(& Q_{VBDC} .front()) == successful*)
17. *Q_{VBDC} .pop();*
18. **if** (*!isEmptyQ(Q_{CRA}) || !isEmptyQ(Q_{RBDC})*)
19. *break; # process CRA queue or RBDC queue*

Once Priority request scheduler, schedules request and hands it over to Resource allocation module, it employs the resource allocation algorithm as shown in Fig.6., selects the appropriate slot avoiding slots which falls inside the forbidden zone and generates terminal burst time plan(TBTP).

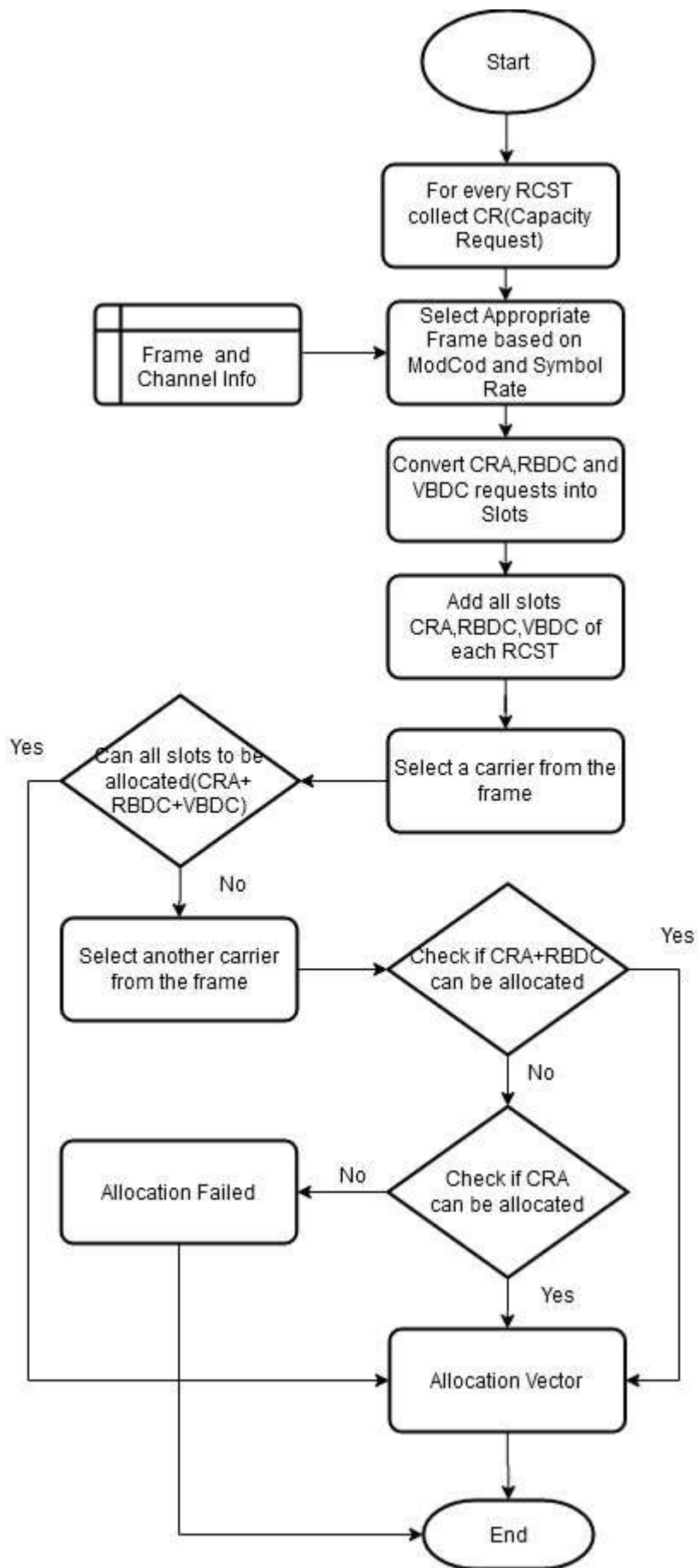

Fig. 6. Flow chart of resource allocation algorithm.

B. Resource Allocation Constraints

The parallel connection arises due to transmission of terminal on more than one frequency at a time. This has to be avoided as data of multiple transmissions will be garbled in a terminal having an antenna. In this scenario, partially or fully overlapping slots in time domain have to be invalidated. This paper details in great length about the scheme for the same. It has introduced the novel concept of ‘forbidden zone’ for a terminal to avoid parallel transmission as well as reduces the search space for finding appropriate slot by excluding all slots which couldn’t be allocated to a terminal. This concept is relatively easy to implement when there is a regular grid of frequency and fixed size time slot in a frame (refer Fig 6 and 7). However, the same issue becomes quite tricky when frequency of carrier changes and correspondingly slot size varies making grid of frequency and time irregular. To formulate forbidden zone following assumptions have been made

- (a) Fixed MF-TDMA is implemented wherein slot size is fixed.
- (b) At a time t any terminal can transmit data only on a single frequency.
- (c) Any terminal T can be allocated maximum up to all the slots of a sub carrier.

• Discussion

Let us suppose, a terminal T_1 is assigned a slot (f_1, t_1) . Other valid assignments for T_1 are $(f_i, t_j), \forall i \leq j$ and invalid assignments for T_1 are $(f_i, t_j), \forall i > j$. Without loss of generality, if terminal T_n is assigned a slot (f_i, t_j) , it is required to define the forbidden zone, i.e. slots which can’t be assigned to terminal T_n . Frequency and Time grid after initial allocation is shown in Fig. 6.

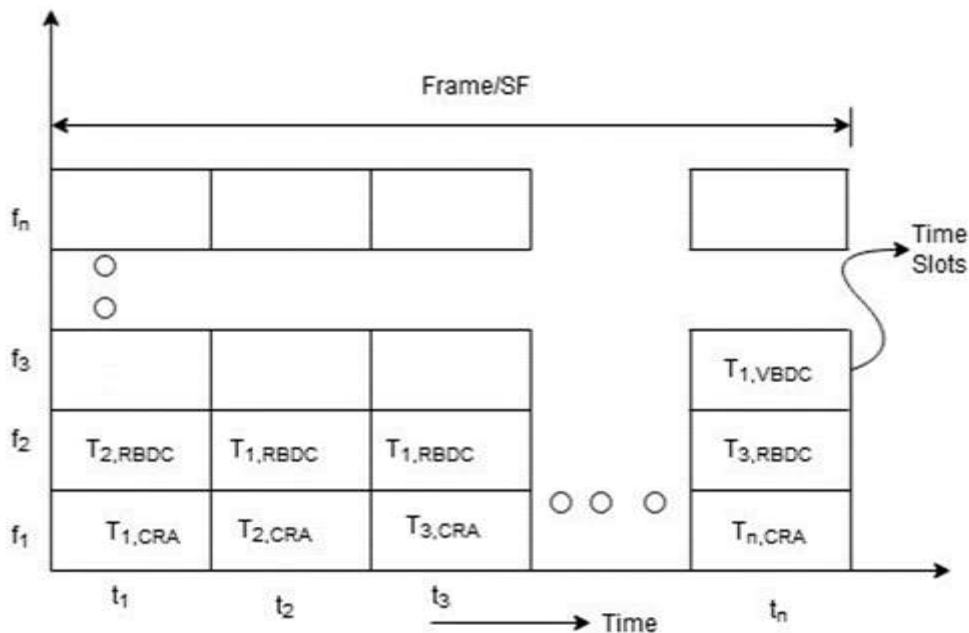

Fig. 7. Frequency time grid after initial allocation

Forbidden zone for a terminal T_1 is shown in figure 7.

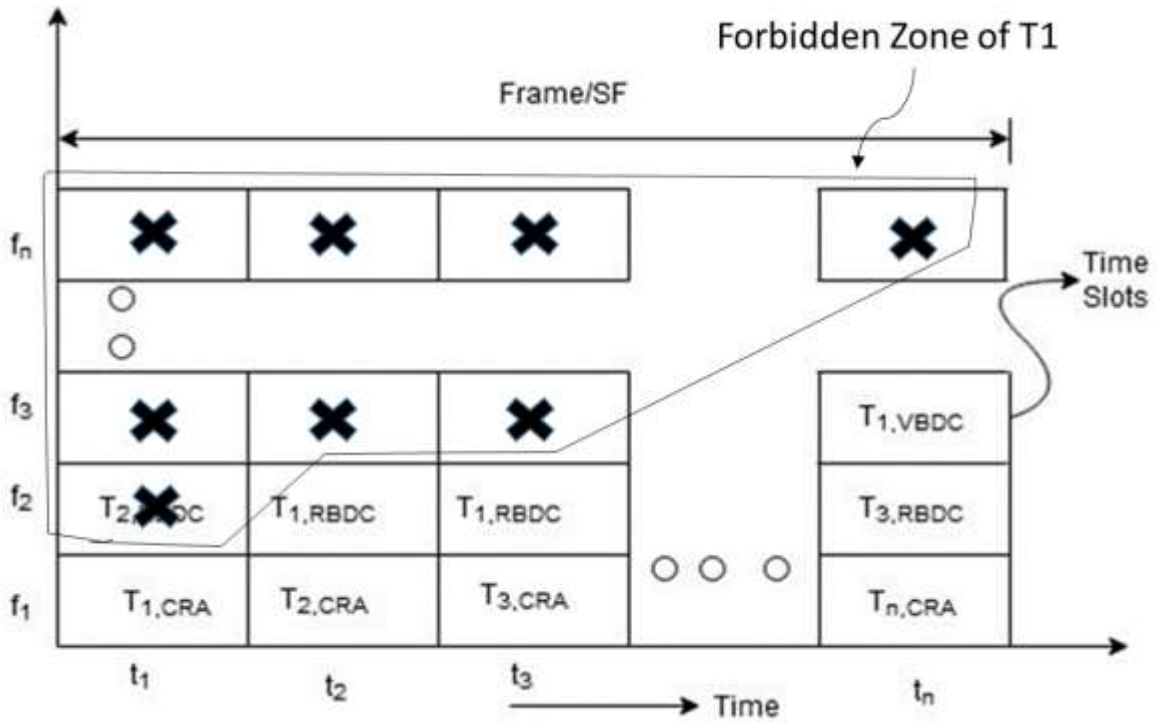

Fig. 8. Forbidden zone of a terminal after initial allocation.

C. Repeating Assignment

Repeating Assignment is applicable for superframe basis. CRA allocation is to be done explicitly in every frame. VBDC and RBDC assignment is to be differentiated based on repeating assignment at RCST. Bandwidth assignment to RCST is uniquely identified by *sf_id*, *superframe_counter*, *frame_number* and *slot_number*. Resource allocation shall be done on RC basis. In each type of RC both types of capacity request are valid as shown in the Table VI.

Table VI
SUMMARY OF REQUEST CLASSES AND CAPACITY CATEGORY

Sl No.	Traffic type	channel_id	Capacity Request Type
1.	EF	1	RBDC/VBDC/AVBDC
2.	AF	2	RBDC/VBDC/AVBDC
3.	BE	3	RBDC/VBDC/AVBDC

D. Resource Deallocation

In SAC burst 16-bit field of *M_and_C_Message* is there. If terminal sets this message to Log-off request(0x0002) and sends this packet to NCC, then NCC deallocates synchronization and traffic

resources of the terminal. After deallocation, NCC sends Terminal Burst Time Plan (TBTP) with Assignment Type to be set assignment release (10).

SAC message is also used for *M_and_C_Message* and if the RCST does not have any capacity request to send, it shall send a VBDC request with an amount of 0[11]. Assignment release may be unreliable, in case of bandwidth squeezing from NCC. If assignment release is not received by RCST, then there might be collision as terminal is unaware of changes in allocation and keeps on transmitting on pre-assigned slot but in actual case some of the previously assigned slots might have been reassigned to some other terminal.

V. Results

In order to meet the QoS requirement of multimedia application, resource allocation must be prioritized. Three RCSTs (T_1, T_2, T_3) are mimicked using three threads which are capable of sending resource request. The capacity request scheduler thread starts little later than T_1, T_2 and schedules the resource request as per the priority of capacity request ($P_{CRA} > P_{RBDC} > P_{VBDC}$). It can be seen in the Fig.8 that T_1 has requested RBDC request prior to the CRA request of T_1 . In this case, since priority of CRA is more than RBDC, T_2 's request of CRA slot will be allocated prior to RBDC request of T_1, T_3 starts after the capacity request scheduler has already started. In this case also firstly the CRA slot will be allocated and then RBDC slot will be allocated.

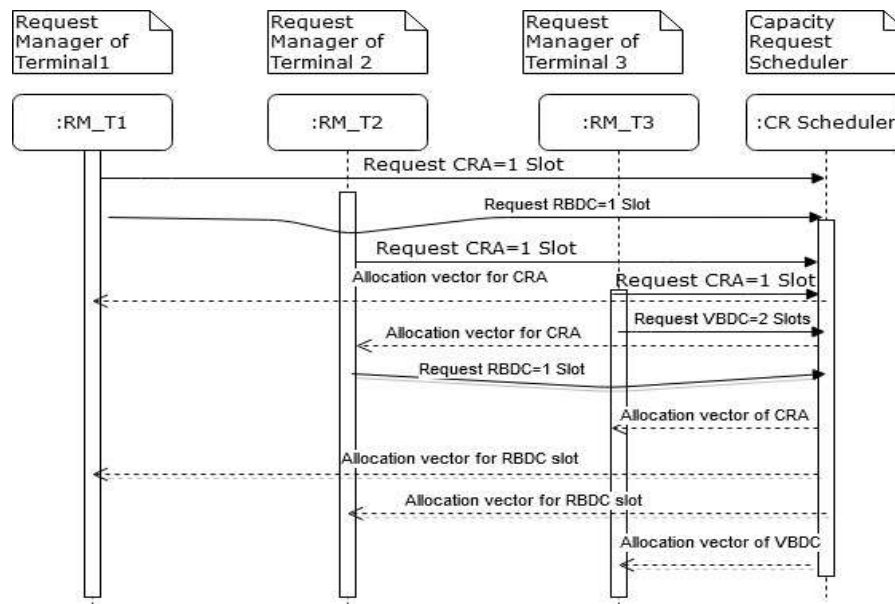

Fig 9. Sequence diagram of testing with three terminals.

Allocation should be done in a manner such that principle of forbidden zone shouldn't be violated. In the allocation grid represents one frame and its row and column represents frequency and time respectively. Each cell represents slots. The value 0 represents that the particular slot is unallocated and if value is equal to terminal ID then it represents that particular slot is assigned with that specific terminal.

```

Request Manager T1 started ...
RM-T1 has requested CRA=1 slot
RM-T1 has requested RBDC=1 slot
Request Manager T2 has started
RM-T2 has requested CRA=1 slot
RM-T2 has requested RBDC=1 slot
Request Manager T3 started...
Capacity Request Scheduler waiting to be started...
TID: 1 Type Of Slot:CRA
TID: 2 Type Of Slot:CRA
TID: 1 Type Of Slot:RBDC
TID: 2 Type Of Slot:RBDC
TID: 1 Type Of Slot:VBDC
*****
Allocation Grid(r:freq,c=time,AG[r,c]:TID,0:unallocated)
*****
1      2      1      2
0      1      0      0
0      0      0      0
0      0      0      0
*****
RM-T3 has requested CRA=1 slot
RM-T3 has requested RBDC=2 slot
TID: 3 Type Of Slot:CRA
TID: 3 Type Of Slot:RBDC
*****
Allocation Grid(r:freq,c=time,AG[r,c]:TID,0:unallocated)
*****
1      2      1      2
3      1      3      3
0      0      0      0
0      0      0      0

```

Fig. 10. Screenshot of the outcome of priority resource allocation.

Result of priority allocation is shown in allocation grid referred in Fig. 10. It can be seen in the fig 9 that CRA request is allocated before RBDC request and RBDC request is allocated before VBDC request. In fig. 10, TDM broadcast is shown. SCT, FCT and TCT are sent. Synchronization resources (ACQ and SYNC slots) are sent in ACQ Assign descriptor(AAD) and SYNC Assign descriptor(SAD). CRA resources are assigned in every frame and intimated to RCST using TBTP as shown in Fig. 11.

```

*****
Allocation Process STARTS
*****
[RRM:RRAllocator]SFT is sent:!!48::
[RRM:RRAllocator]FCT is sent:!!2065::
[RRM:RRAllocator]TCT is sent:!!131::
[RRM] SF No: 2 time(msec):8260483
[LH]MAC ID:0:0:0:0:1 Terminal Profile is found
[LH]Course Res->TID:1 SF No: 7 Frame No: 0 Acq Slot No:2 Rep Period:1

[LH]Sync Res->TID:1 SF No: 7 Frame No: 0 Sync Slot No:3 Rep Period:1

[LH]TIM-U is sent from NCC ...

[RRM] SF No: 3 time(msec):8260675
[RRM:RRAllocator]TBTP is sent:!!120::
[RRM]TBTP is printing...No Of Frames:4
[RRM]TBTP Frame No:0 BTP Size:1
[RRM] TID:1 Channel ID:1 Start SlotNo:7 Assignment Count:1 Assignment Type(repeating:1, One time:0 Assignment Release:2) :1
[RRM]TBTP Frame No:1 BTP Size:1
[RRM] TID:1 Channel ID:1 Start SlotNo:7 Assignment Count:1 Assignment Type(repeating:1, One time:0 Assignment Release:2) :1
[RRM]TBTP Frame No:2 BTP Size:1
[RRM] TID:1 Channel ID:1 Start SlotNo:7 Assignment Count:1 Assignment Type(repeating:1, One time:0 Assignment Release:2) :1
[RRM]TBTP Frame No:3 BTP Size:1
[RRM] TID:1 Channel ID:1 Start SlotNo:7 Assignment Count:1 Assignment Type(repeating:1, One time:0 Assignment Release:2) :1

```

Fig.11. Screenshot of the outcome of CRA allocation.

RBDC request is done per RC basis. For RC Index 1 a request of 32 Kbps has done in response to this a single slot is allocated as single slot is capable of sending 32 kbps. TBTP is shown in Fig. 12.

```

-----
CRA BW(Kbps):0 RBDC BW(Kbps):8 VBDC BW(Kbps):8
-----
RC Index:1
-----
CRA BW(Kbps):0 RBDC BW(Kbps):32 VBDC BW(Kbps):8
-----
RC Index:2
-----
CRA BW(Kbps):0 RBDC BW(Kbps):8 VBDC BW(Kbps):8
-----
[RRM]LogonID:1 BW[1]RBDC(In Kbps):32 NO of Slots:1
[RRM] Allocation Succeeds for RBDC!! Allocated Slot: 1
[RRM:RRAllocator]TBTP is sent:!!21::
[RRM]TBTP is printing...No Of Frames:1
[RRM]TBTP Frame No:0 BTP Size:1
[RRM] TID:1 Channel ID:1 Start SlotNo:8 Assignment Count:1 Assignment Type(repeating:1, One time:0 Assignment Release:2) :1

```

Fig.12. Screenshot of the outcome of RBDC Allocation

In Fig. 13., terminal having login ID 1 is getting log off. All the resources of terminal such as traffic and synchronization resources shall be freed.

```

[RRM]Login ID:1 has initiated LOG OFF...
[RRM]Deallocation of TID:1 traffic resources succeeds....
[RRM]Deallocation of TID:1 traffic resources(CRA) succeeds....
[RRM]Deallocation of TID:1 ACQ sync resources succeeds....
[RRM]Deallocation of TID:1 Fine Sync resources succeeds....

[RRM:RRAllocator]TBTP is sent:!!87::

```

Fig.13. Screenshot of the outcome of Log Off procedure

Resource allocation technique for DVB-RCS compliant terminals is realized on PC. More generic resource allocation algorithm needs to be developed wherein slots of variable time period can be catered.

VI. CONCLUSION

DVB-RCS resource allocation is quite challenging to implement due to many factors such as complex and voluminous data structures of control and traffic packets, return link capacity categories while requesting resources, MF-TDMA in return link and ACM mechanism etc. In this paper, authors have brought out the important features of DVB-RCS system focusing mainly on the crux of standard i.e. resource allocation. Authors have developed resource allocation constraints wherein forbidden zone for a terminal has been evolved as referred Fig. 6 and Fig. 7) and implemented the resource allocation algorithm suited for multimedia applications. Since, multimedia applications are delay and jitter sensitive, resource allocation must be suited to QoS requirement of multimedia application. In order to maintain QoS requirements, priority resource allocation has been developed, wherein resources are allocated based on the priority of capacity category. This software has implemented non-contiguous assignment. More generic resource allocation algorithm needs to be developed wherein slots of variable time period can be catered.

Declaration

- Ethics approval and consent to participate :NA
- Consent for publication:NA
- Availability of data and material:NA
- Competing interests:No

- Funding:No
- Authors' contributions
 - Abhishek Kumar Roy:Design and Implementation
 - Rajneesh Singhal:Design and Implementation
 - Dr. Trilok K. Saini:Software Architecture
 - Satyendra Kumar:Preliminary suggestion
 - Manoj K. Dhaka:Preliminary suggestion
- Acknowledgements:NA

REFERENCES

- [1] Borja de la Cuesta, Lorena Albiol, Javier M Aguiar, Carlos Baladrón¹, Belén Carro and Antonio Sánchez- Esguevillas, “Innovative DAMA algorithm for multimedia DVB-RCS system”, EURASIP Journal on Wireless Communications and Networking 2013.
- [2] Antoni Morell, Gonzalo S. and Maria A., “Cross-Layer Design of Dynamic Bandwidth Allocation in DVB-RCS”, in IEEE Systems Journal, vol 2, no 1, March 2008.
- [3] Senior Member, IEEE, Roy Leirvik, Jan Hetland, Helge Fanebust, and Vendela Paxal, Member, IEEE, “Interactive IP-Network Via Satellite DVB-RCS Harald Skinnemoen” in IEEE Journal on Selected Areas in Communications, vol. 22, no. 3, April 2004.
- [4] Dionysia K. Petraki, Markos P. Anastasopoulos and Panayotis G. Cottis , “Dynamic resource allocation for DVB-RCS networks”,International Journal of Satellite communications Int. J. Commun. Syst. Network 2008; 26:189–210. DOI: 10.1002/sat.908
- [5] Beylot AL., Dhaou R., Baudoin C., “Resource Allocation in DVB-RCS Satellite Systems,” in IEEE Journal on Selected Areas in Communications, vol. 22, no. 3, pp. 546-558, April , 2007.
- [6] N.G.Vasantha Kumar, Mohanchur Sarkar, Vishal Agarwal, B.P. Chaniara,S.V.Mehta,V.S.Palsule, K.S.Dasgupta, “Digital video broadcast return channel via satellite (dvb-rcs) hub for satellite based e-learning”, The International Journal of Multimedia & Its Applications (IJMA),vol. 3,no.1,February 2011.DOI: 10.5121/ijma.2011.3112 133.
- [7] Mohamed Al-mosawi, Rinat Khusainov, Boris Gremont , “A Real Time Algorithm for Bandwidth and Time-slot Assignment for Rain Faded DVB-RCS Systems, The Fourth International Conference on Advances in Satellite and Space Communications ”, SPACOMM 2012 .
- [8] Kyu-Hwan Lee and Kyoung Youl , “Overall Design of Satellite Networks for Internet Services with QoS”, MDPI Journal Electronics, June, 2019.
- [9] Dan Xu, Xin Liu and Athanasios V. Vasilakos, “Traffic-Aware Resource Provisioning for Distributed Clouds”, IEEE Cloud Computing, March, 2015.DOI: 10.1109/MCC.2015.22
- [10] Sangjoon Jung¹, Chonggun Kim², and Younky Chung^{1M} , “A Prediction Method of Network Traffic Using Time Series Models,ICCSA 2006, LNCS 3982, pp. 234 – 243, 2006.
- [11] ETSI, Digital Video Broadcasting (DVB). Interaction channel for satellite distribution systems. Guidelines for the Use of EN 301 790 ETSI TR 101 790 V1.3.1, 2006–2009.
- [12] F. Delli Priscoli, A. Pietrabissa, “Design of a bandwidth-on-demand (BoD) protocol for satellite networks modeled as time-delay systems”, Automatica, Vol. 40, Issue 5, pp. 729-741, May, 2004.

[13] Mitchell, P. D., Grace, D. & Tozer, T.C. "Burst Targeted Demand Assignment Multiple-Access for Broadband Internet Service Delivery Over Geostationary Satellite", IEEE Journal on Selected Areas in Communications, Vol. 22, N. 3, pp. 546-558, April 2004.

[14] Y. Feng, "Resource allocation in Ka-band satellite systems," Master. Dissertation, Dept. of Electrical and Computer Engineering, University of Maryland, 2001.

[15]. A.K. Roy, R.K. Agrawal, M.K. Dhaka, S. Kumar, T. K. Saini, and R. Singhal, "Optimal utilization of satellite bandwidth for TDM/TDMA channel access scheme," International conference on Signal processing and Integrated Networks, Feb 2015, pp. 315-317.

[16]. T.K. Saini, R. K. Agrawal, M. K. Dhaka, and S. Kumar, "Realization of NCMS based on SCPC DAMA for SATCOM Network," International conference on Signal processing and Integrated Networks, Feb 2015, pp. 311-314.