

In-vitro & In-vivo Investigation of the Silicon Nitride Ceramic Hip Implant's Safety and Effectiveness Evaluation

Xiangpeng Kong

Chinese PLA General Hospital

Xiaosu Hu

Suzhou Black Ceramic Medical Technology Co., Ltd.

Wei Chai (✉ chaiweiguanjie@sina.com)

Chinese PLA General Hospital <https://orcid.org/0000-0001-8781-9745>

Research Article

Keywords: silicon nitride, ceramic femoral head, hip replacement, in-vitro & in-vivo experiments

Posted Date: November 12th, 2021

DOI: <https://doi.org/10.21203/rs.3.rs-983296/v1>

License: © ⓘ This work is licensed under a Creative Commons Attribution 4.0 International License. [Read Full License](#)

Version of Record: A version of this preprint was published at Journal of Orthopaedic Surgery and Research on February 12th, 2022. See the published version at <https://doi.org/10.1186/s13018-021-02884-7>.

Abstract

Background: With regard to the ceramic hip joint implant, given the concerns in ceramic about the alumina brittleness and zirconia instability, is there any alternative material solution for the orthopaedic implant? Beyond the metastable oxide ceramics, along the echelon of advanced technical ceramics, looking at the non-oxide ceramic, the silicon nitride could be an excellent candidate for the joint implant's application. The purpose of this study is to investigate the safety, effectiveness and to demonstrate the potential of this silicon nitride hip implant.

Methods: According to the related ISO (International Organization for Standardization) standards, a series of *in-vitro* (nine) & *in-vivo* (five) tests, which had been accomplished for the aforementioned aim. Especially, the total hip replacement in pigs had been achieved, as per the authors' knowledge, this is the first time to apply the THA (Total Hip Arthroplasty) in the big animal.

Results: Refer to the ISO 6474-2, in comparison with the current monopolized German product, this silicon nitride ceramic hip implant has high strength, high hardness, excellent fracture toughness, lower density, better wear resistance, good biocompatibility, inherent stability, corrosion resistance and bioactivity, bone integration capability.

Conclusions: This silicon nitride ceramic will be an admirable alternative solution with superior comprehensive property that can withstand the toughest conditions in the most demanding applications like in orthopedic and beyond.

1. Introduction

With the increasing trend of Chinese aging population and the continuous improvement of life expectancy and living standards, people's awareness of healthy life has changed, currently Total Hip Arthroplasty (THA) is gradually admitted and accepted in China, it is also usually recognized as one of the most successful modern surgery^[1].

Meanwhile, with regard to the avascular necrosis of the femoral head, the demands from the relative young patients have been raised due to the alcoholic or sportive traumata or genetic predilection. As the last resort, THA will restore these patients' health^[2].

A safe, effective and durable hip implant is desirable consequently.

In terms of the material improvement, compared with John Charnley's metal femoral head^[3], the introduction of ceramic in THA was a great initiation since almost five decades ago^[4].

Considering the appreciated excellent biological behavior, no metal ion release, no known pathogenic reaction to particles, excellent wettability, resistant to third-body wear, significantly low taper corrosion *etc.*, thanks to these inherent properties of ceramic, more than 18 million oxide ceramic components are sold since 1974 by the monopolized German giant^[5].

However, the poor toughness is the biggest demerit of the alumina ceramic^[6], in order to solve the problem of alumina brittleness, zirconia, one of the highest strength ceramics, has been widely used as femoral head since 1985^[7,8].

Nevertheless, this metastable zirconia ceramic for medical use were suspended on August 14, 2001 by Saint-Gobain Desmarquest (Vincennes, France) and a Medical Device Recall Notice was issued one month later by the FDA (U. S. Food and Drug Administration)^[9] due to the catastrophic experience with Prozyr[®] femoral head produced by this world's largest supplier of medical-grade stabilized zirconia ceramic^[10].

The root cause of this failure is the inherent zirconia phase transformation. By a stress corrosion mechanism, the initial phase transformation of isolated grains occurs on the machined and polished surfaces, where is not only the femoral head bearing surface, but also the inner taper surface in contact with the femoral stem. The zirconia transforms from metastable tetragonal to monoclinic phase, this phase change results a volumetric expansion in the grains that induces a compressive stress increase and leads to the propagation of the micro cracks and surface roughened^[11].

Under more severe environment, especially with presence of moisture, like in the human body, this zirconia intrinsic aging process will transform more aggressively to the monoclinic phase with catastrophic consequence: increased wear, grain pull-out and generation of particle debris even through the premature failure^[12].

Given the concerns about the monolithic alumina brittleness and zirconia instability, to counteract these deficiencies, different approaches have been proposed like developing alumina-zirconia composites: ZTA (Zirconia Toughened Alumina) or replacing yttria with other additives such as ceria to stabilize zirconia.

Although zirconia transformation toughening effect is well appreciated, it is also exceedingly complex and still not totally understood.

I. C. Clarke *et al.* [11] and J. Chevalier [12] tried to pierce the veil of mystique surrounding zirconia. The potential effect of different process stages on microstructure of zirconia and consequently on phase transformation and aging were summarized. And it is remarkable that that ageing could be significant in the alumina-3Y-TZP (Yttria-stabilized Tetragonal Zirconia Polycrystal) composite above 16 vol% zirconia. This critical content was related to the percolation threshold above which a continuous path of zirconia grains allowed transformation to proceed. The latter author also emphasized that, for alumina–zirconia composite, the presence of zirconia aggregates, especially if the zirconia is stabilized with yttria, should be avoided [12].

From some orthopedic surgeons' point of view, it is unsatisfactory to implant a material into the body, which is not fully stable.

In this respect, beyond the metastable oxide ceramics, along the echelon of advanced technical ceramics, looking at the non-oxide ceramic, the silicon nitride could be a suitable alternative material solution for joint implants.

The purpose of this paper is to investigate the silicon nitride hip implant's safety and effectiveness via *in-vitro* and *in-vivo* experiments then to demonstrate the applicability and potential of this silicon nitride ceramic in the orthopedic domain.

2. Materials & Methods

In this study, a series of *in-vitro* (nine) & *in-vivo* (five) tests had been designed, 5 *in-vitro* tests were descriptive, the rest other 4 *in-vitro* tests and 5 *in-vivo* tests were analytic. And the level of evidence is Level I since the 5 *in-vivo* tests were all randomized controlled trials.

The approval was obtained from the Institutional Review Board of Chinese PLA General Hospital prior to performing the study.

2.1 Specimens Tested

According to the specific requirements defined by the related ISO standards, the relevant silicon nitride specimens were prepared for two categories experimentation: *in-vitro* & *in-vivo* experiments. Both sample bars (Figure 1) and femoral heads (Figure 2) were produced via the patented material formula and technological process by Black Ceramic Medical Technology Co., Ltd. (Suzhou, China). The geometrical dimension and tolerance of the femoral head were detailed in the Figure 3.

As per the animal CT (Computed Tomography) scan data, the femoral stem was customized in wrought cobalt-chromium-molybdenum alloy by 3D printing from LDK Technology Co., Ltd. (Beijing, China), the cemented acetabular cup was made of UHMWPE (Figure 4).

Thirteen health Bama minipigs (Figure 5) were purchased from Beijing Strong Century Minipigs Breeding Base. Minipigs were fed in Laboratory Animal Center of Chinese PLA (People's Liberation Army of China) General Hospital (Beijing, China), with a 12:12-hour light-dark cycle, room temperature maintained between 20°C and 22°C and humidity range 50–60%, for one week prior to experiment in order to adapt to environment. The Bama minipigs' weight was between 25kg and 29kg. All animal care and procedures were approved by the Animal Care Committee of Chinese PLA General Hospital and complied with the latest guideline.

2.2 In-vitro experiments

2.2.1 Accelerated ageing test

Within the domain of hip implants, the accelerated ageing is usually a test method for investigating the oxidative stability of Ultra-High-Molecular-Weight-Polyethylene (UHMWPE) materials as a function of processing and sterilization method. The UHMWPE is aged at elevated temperature and at elevated oxygen pressure, to accelerate oxidation of the material and thereby allow for the evaluation of its potential long-term chemical and mechanical stability. The related principle, process and requirements are calibrated in (ISO 5834-3).

However, with regard to the ceramics applied as orthopedic prostheses, especially for the metastable oxide ceramics like zirconia or its composites, unfortunately for ageing or accelerated ageing, there is no any standard or reference on which could be relied.

Several authors reported that the ageing zirconia could be achieved by means of autoclave treatment at 134°C and 2 bars of pressure. Under this configuration, it was calculated that 1 hour exposure had theoretically the similar effect as roughly 3~4 years in the human body.

In this study, the silicon nitride sample bars (30 pieces) and eight femoral heads had been aged via 10 hours autoclave treatment (134°C, 2 bars) for the following tests.

2.2.2 Elastic moduli test

According to (ISO 17561), ten specimens unaged had been tested at room temperature for determining the Young's modulus by sonic resonance.

2.2.3 Flexural strength test

As per (ISO 14704), ten specimens unaged with another ten specimens aged by using process defined in section 2.2.1 had been investigated correspondingly for obtaining the average flexural strength in four-point-1/4 point flexure with 40 mm span semi-articulating fixtures and the bearings were free to roll.

2.2.4 Fracture toughness test

Considering the material proprieties, the notch feasibility and accuracy, the indentation fracture method had been adopted for evaluating the fracture resistance of silicon nitride. In accordance with (ISO 21618), ten specimens unaged and aged had been examined respectively with an indentation load of 98.07 N.

2.2.5 Fatigue strength test

As a pass/fail test for determination of the overall fatigue behavior, consistent with (ISO 22214), five specimens unaged and aged had been carried out separately at room temperature in air ($25\pm 5^{\circ}\text{C}$, $\text{RH}40\pm 10\%$). The four-point-1/4 point flexure with 40 mm span semi-articulating fixtures had been used. The waveform of loading stress is a sinusoidal wave of 10 Hz frequency and a stress ration $R=0.1$. The minimum and maximum force applied were 50 N and 500 N respectively. The number of cycles for suspension was set at 10 million.

2.2.6 Vickers hardness test

Refer to (ISO 14705), five specimens unaged and aged had been inspected respectively for determining the Vickers hardness at room temperature in air. The test force used was 98.07 N.

2.2.7 Cytotoxicity test

According to (ISO 10993-5), in this study, the end-point measured in cytotoxicity determination was the measurement of cell growth via the extract test. The related materials and methods were detailed in the Appendix due to the constraint on length of body text.

2.2.8 Salmonella typhimurium reverse mutation assay/Ames test (OECD - Organization for Economic Co-operation and Development 471)

As per (ISO 10993-3) and OECD 471 guideline, the specimen's genotoxicity, gene mutations in bacteria, its mutagenicity had been investigated via the number of colonies observed. The related materials and methods were detailed in the Appendix due to the constraint on length of body text.

2.2.9 TK gene mutation test using mouse lymphoma cells (OECD 476)

Refer to (ISO 10993-3) and OECD 476 guideline, the specimen's genotoxicity, gene mutations in mammalian cells, had been evaluated via the observation of mouse lymphoma cells (L5178Y TK^{+/}-3.7.2C)' forward mutation. The related materials and methods were detailed in the Appendix due to the constraint on length of body text.

2.2.10 Mammalian chromosome aberration test (OECD 473)

In accordance with (ISO 10993-3) and OECD 473 guideline, the specimen's genotoxicity, clastogenicity in mammalian cells, had been examined via the inducement of chromosome aberration in the Chinese Hamster Lung (CHL) cells. The related materials and methods were detailed in the Appendix due to the constraint on length of body text.

2.3 In-vivo experiments

2.3.1 Acute & sub chronic systemic toxicity test

According to (ISO 10993-11), for the acute systemic toxicity test, 20 mice randomized in 4 groups had been involved, the related materials and methods were detailed in the Appendix due to the constraint on length of body text.

2.3.2 Irritation test

As per (ISO 10993-10), with regard to the test material, its potential to produce irritation had been assessed via the animal skin irritation test. The related materials and methods were detailed in the Appendix due to the constraint on length of body text.

2.3.3 Delayed-type hypersensitivity test

Refer to (ISO 10993-10), for the silicon nitride in this study, its delayed-type hypersensitivity had been evaluated via the guinea pig maximization test. The related materials and methods were detailed in the Appendix due to the constraint on length of body text.

2.3.4 Test for local effects after implantation in bone

In accordance with (ISO 10993-6), the local effects after implantation had been investigated via the implantation test in rabbit femur with cylindrical implants 2 mm in diameter and 6 mm in length. The related materials and methods were detailed in the Appendix due to the constraint on length of body text.

2.3.5 Total hip implantation test in pigs

Three mini pigs were randomly chosen and involved in preliminary experiment for being proficient in approach and surgical technique. And then, ten Bama minipigs were randomly divided into the test group (with total hip arthroplasty) and control group (with arthrotomy) regardless the gender.

Before surgery, a CT scan was accomplished for ensuring its anatomical status. The general anesthesia and trachea cannula were employed. The operating side was randomized on hind legs, a lateral approach was adopted. After disinfection and draping, lateral muscles were cut to expose the hip joint. Then a swing saw was used to cut off femoral neck, then the femoral head was removed and the acetabulum was exposed. The appropriate acetabular reamer was used to clear acetabulum. And a dislocation hook was used to lift femur and medullary space was prepared. After these preparation, acetabular cup impacted and femoral stem inserted, they were fixed by bone cement. The silicon nitride ceramic femoral head was implanted subsequently. After testing the stability of the joint, the incision was closed layer by layer. The blank control group finished arthrotomy with the same approach (Figure 6).

From left to right: Lateral position, disinfection & draping – hip joint exposure – acetabular preparation – prosthesis implantation

After surgery, in order to reduce the risk of blood loss, infection, and pain release, tranexamic acid ($1\text{g}100\text{ml}^{-1}$ *per os*), ceftriaxone sodium (0.25g intramuscular injection), and pethidine (2mgkg^{-1} intramuscular injection) were applied. The clinical observations had been made weekly, the hematology and clinical biochemical determination on blood had been analyzed and recorded monthly. The second CT scan had been accomplished just before the animal euthanasia which was carried out at the end of three months after the implantation, whereafter, the pathology examination had been conducted.

3. Results

According to the related ISO standards, by using the materials and methods detailed in Section 2, the results obtained are summarized in the relevant tables and paragraphs hereunder.

3.1 In-vitro experiments

3.1.1 Elastic moduli test

Specimen No.	Young's modulus (GPa)
01	296
02	301
03	300
04	302
05	296
06	294
07	302
08	302
09	301
10	297
Mean	299
SD	3

3.1.2 Flexural strength test

Specimen No. (Unaged)	Flexural strength (MPa)	Specimen No. (Aged)	Flexural strength (MPa)
11	711	21	862
12	790	22	782
13	853	23	741
14	815	24	733
15	813	25	825
16	725	26	808
17	854	27	724
18	756	28	790
19	875	29	776
20	770	30	840
Mean	796	Mean	788
SD	53	SD	44

3.1.3 Fracture toughness test

Specimen No. (Unaged)	Fracture toughness (MPa·m ^½)	Specimen No. (Aged)	Fracture toughness (MPa·m ^½)
31	6.05	41	6.35
32	6.40	42	6.21
33	6.33	43	6.29
34	6.16	44	6.27
35	6.19	45	6.36
36	6.29	46	6.12
37	6.25	47	6.16
38	6.18	48	6.24
39	6.36	49	6.26
40	6.26	50	6.30
Mean	6.25	Mean	6.26
SD	0.10	SD	0.07

3.1.4 Fatigue strength test

On conditions detailed in Section 2.2.5, both unaged and aged specimens passed the 10 million loading cycles without any failure or intergroup difference either.

3.1.5 Vickers hardness test

Specimen No. (Unaged)	Hardness (HV10)	Specimen No. (Aged)	Hardness (HV10)
61	1426	66	1426
62	1460	67	1436
63	1460	68	1460
64	1449	69	1426
65	1460	70	1467
Mean	1451	Mean	1443
SD	13	SD	17

3.1.6 Cytotoxicity test

On conditions detailed in Section 2.2.7, based upon the comparison with the positive, negative and reagent controls, the relative cell proliferation had been investigated and the qualitative evaluation had been carried out as well. Microscopically, in the majority of cells, there was no changes in general morphology, vacuolization, detachment and membrane integrity. Only few cell lysis had been observed. The cytotoxicity scale was consequently scored as 1, mildly cytotoxic, which is totally acceptable for the intended use.

3.1.7 Salmonella typhimurium reverse mutation assay/Ames test (OECD 471)

On conditions detailed in Section 2.2.8, comparing with the reagent controls, the inhibition of 5 types of salmonella typhimurium had not been observed in the test groups with polar or non-polar solvents. And therefore the specimen's genotoxicity, gene mutations in bacteria, was negative.

3.1.8 TK gene mutation test using mouse lymphoma cells (OECD 476)

On conditions detailed in Section 2.2.9, the reagent controls was used as the baseline, with regard to the mouse lymphoma cells forward mutation, the mutant frequency ratio of the test groups with polar or non-polar solvents and the reagent controls was inferior to 2. And the specimen's genotoxicity, gene mutations in mammalian cells, was consequently negative.

3.1.9 Mammalian chromosome aberration test (OECD 473)

On conditions detailed in Section 2.2.10, according to the response of reagent controls, regarding the chromosome aberration in CHL cells, there was no statistical difference ($p>0.05$) between the test groups and the reagent controls. And accordingly, the specimen's genotoxicity, clastogenicity in mammalian cells, was negative.

3.2 In-vivo experiments

3.2.1 Acute & sub chronic systemic toxicity test

Under the circumstances detailed in Section 2.3.1, regardless of the test groups with polar/non-polar solvents or reagent controls, the clinical observation was all normal for each mouse at the different inspection points. And during the observation period, all the body weights were increased and the mortality was zero. In one word, the specimen's acute systemic toxicity was negative.

For the subchronic systemic toxicity, in accordance with the reagent controls, in terms of the clinical observation, bodyweight change, hematology, clinical biochemical determination on blood, gross pathology and histopathology, there was no statistical difference ($p>0.05$) between the test and control groups. As a result of which, the specimen's subchronic systemic toxicity was negative.

3.2.2 Irritation test

Under the circumstances detailed in Section 2.3.2, irrespective as to whether test groups with polar/non-polar solvents or reagent controls, no any erythema or eschar or oedema occurred, upon which, the specimen's response to irritation test was negative.

3.2.3 Delayed-type hypersensitivity test

Under the circumstances detailed in Section 2.3.3, regardless of the test groups with polar/non-polar solvents or reagent controls, the clinical observation was all normal for each Hartley albino guinea pig during the observation period. There was no any erythema or oedema observed. Based upon the patch test reactions, according to the Magnusson & Kligman scale, the grading score obtained was less than 1. Consequently, the specimen's response to delayed-type hypersensitivity test was negative.

3.2.4 Test for local effects after implantation in bone

Under the circumstances detailed in Section 2.3.4, for both the test and control group, there was no abnormal local effects observed through the 26 weeks after the implantation. 1 week after implantation, a few fibrous osteoid callus were similarly observed around the test and control sample. 4 weeks after the implantation, the test and control specimen engaged closely with bone tissue, cell proliferation and trabeculae were observed equally. 26 weeks after the implantation, the new bone formed healthily around the test and control sample, the densified cortical bone were observed, there was no any foreign body reaction. In conclusion, the specimen's response to local effects after implantation in bone was negative.

3.2.5 Total hip implantation test in pigs

Under the circumstances detailed in Section 2.3.5, comparing with the control group, all the samples in test group were functioning well through the observation period (Figure 7). The blood test results were normal, in terms of the C-reactive protein and erythrocyte sedimentation rate, there was no difference between the test and control group. The CT scan results reveal the good outcome (Figure 8). And the pathology examination results were negative. More detailed information could be found in another clinical report.

4. Discussion

This study presents a thorough scenograph, from material level to product level, of the specific silicon nitride used as the femoral head in total hip implant system.

Comparing with the current monopolized product, BIOLOX[®] delta femoral head from CeramTec (Plochingen, Germany), this ZTA product's performance is regularized by (ISO 6474-2), Black Ceramic[®] silicon nitride femoral head has the comparable mechanical performance.

Meanwhile, the latter's fracture toughness is even better, the density is lower, the related implant will be lighter consequently, and exclusively, without the concern about the zirconia's aging and instability, which are caused by the inherent and inevitable phase transformation.

Based upon the current test results obtained, the silicon nitride in this study has a superior oxidation resistance since its mechanical performances are almost indistinguishable between the unaged and aged group.

Although the accelerated ageing method adopted in this study will permit an investigator to compare the oxidative stability of silicon nitride, it is recognized that it may not precisely simulate the degradative mechanisms for an implant during real time shelf ageing and implantation. And concerning shelf ageing component, the package environment other than air is not taken into account, the related effect could be possibly not negligible.

It is important to emphasize that, comparing with the metastable oxide ceramics, the silicon nitride could withstand more severe ageing method without performance degradation due to its unique, innate and outstanding integrated characteristics.

In the orthopedic domain, the implant's wear performance is crucial as well. Although the silicon nitride is well known as a self-lubricated material, its wear resistance as the hip joint prosthesis still needs to be demonstrated according to ISO 14242 which is also the regulatory prerequisite. There are several simulator studies have been accomplished^[13,14,15]. Recently, S. Affatato *et al.* accomplished the first *in-vitro* wear behavior comparison between silicon nitride and ZTA head, the results are very promising^[16].

With regard to the first ceramic total hip replacement in big animal of three month observation, it is definitely not long enough for investigating its wear performance, which is the reason for what to continue the animal study and to deploy the appropriate hip simulator test as well.

However, in the context of (ISO 14242-1), among the current simulated conditions, it is worthwhile to investigate the more realistic wear performance under the slow-speed, high-loads with shock and interrupted (stop-start) conditions, in addition, more important, the edge loading, ageing and wearing are occurred simultaneously^[17]. In this respect, beyond the metastable oxide ceramics, along the echelon of advanced technical ceramics, looking at, the non-oxide, real stable ceramic, the silicon nitride, its potential and advantages will be highlighted contrastively.

Furthermore, G. Pezzotti *et al.* revealed that the oxidation rate of polyethylene liners was greater when coupled with oxide as opposed to non-oxide ceramic heads^[18,19,20]. And in addition, J. Webster *et al.* discovered for the first time that without the use of antibiotics, the bacteria colonization was reduced and bone formation was increased on the silicon nitride surface compared with titanium and PEEK^[21,22,23].

5. Conclusion

Through all these *in-vitro* & *in-vivo* experiments, this silicon nitride hip implant's safety and effectiveness have been investigated.

Comparing with the present metastable oxide ceramics, silicon nitride has the right combination of high strength, high hardness, excellent fracture toughness, lower density, better wear resistance, good biocompatibility, inherent stability, corrosion resistance and bioactivity, bone integration capability, all of which are desirable in medical implants.

Due to the excellent combination of properties, this silicon nitride will be an excellent material that can withstand the toughest conditions in the most demanding applications like in orthopedic and beyond.

Abbreviations

ISO International Organization for Standardization

THA Total Hip Arthroplasty

FDA U. S. Food and Drug Administration

ZTA Zirconia Toughened Alumina

3Y-TZP Ytria-stabilized Tetragonal Zirconia Polycrystal

CT Computed Tomography

PLA People's Liberation Army of China

UHMWPE Ultra-High-Molecular-Weight-Polyethylene

OECD Organization for Economic Co-operation and Development

CHL Chinese Hamster Lung

DMSO Dimethyl Sulfoxide

NCTC National Collection of Type Cultures

SC Sodium Chloride

RPMI Roswell Park Memorial Institute

CSO Cottonseed Oil

IV Intravenous

IP Intraperitoneal

BW Body Weight

FCA Freund's Complete Adjuvant

Declarations

Ethics approval and consent to participate

All animal care and procedures were approved by the Institutional Review Board / Animal Care and Use Committee of Chinese PLA General Hospital and complied with the latest related guideline and the relevant ethics approval is obtained.

Consent for publication

Not applicable.

Availability of data and materials

The datasets generated and/or analysed during the current study are not publicly available due to the data also forms part of an ongoing study, but are available from the corresponding author on reasonable request.

Competing interests

Co-first author, Xiaosu Hu is the CEO of Suzhou Black Ceramic Medical Technology Co., Ltd. The other authors declare that they have no known competing financial interests or personal relationships that could have appeared to influence the work reported in this paper.

Funding

This study was funded by the National Natural Science Foundation of China (Grant-Number: 81772320).

Authors' contributions

All authors have made substantial contributions to: (1) the conception and design of the study, (2) drafting the article or revising it critically for important intellectual content, (3) final approval of the version to be submitted.

Xiangpeng Kong: Conceptualization, methodology, investigation, writing original draft, visualization, project administration.

Xiaosu Hu: Methodology, investigation, writing original draft, visualization, animal handling.

Xiangpeng Kong and Xiaosu Hu contributed equally to this work.

Wei Chai: Conceptualization, methodology, investigation, resources, writing original draft, visualization, supervision, project administration, funding acquisition.

Acknowledgements

All the silicon nitride components are offered by Black Ceramic Medical Technology Co., Ltd. (Suzhou, China), the metal femoral stems, acetabular cups are provided by LDK Technology Co., Ltd. (Beijing, China). Without the help from Shanghai Institute of Ceramics of the Chinese Academy of Sciences, Jinan Quality Supervision and Inspection Center for Medical Devices of National Medical Products Administration, Orthotek Laboratory (Shanghai, China) and Laboratory Animal Center of Chinese PLA General Hospital (Beijing, China), this work could not be accomplished, the authors would like to express the special thanks for their great contribution.

Normative References

1. "ISO 10993-10." *Biological evaluation of medical devices – Part 10: Tests for irritation and skin sensitization*. 2010. <<https://www.iso.org/standard/40884.html>>.
2. "ISO 10993-11." *Biological evaluation of medical devices – Part 11: Tests for systemic toxicity*. 2017. <<https://www.iso.org/standard/68426.html>>.
3. "ISO 10993-3." *Biological evaluation of medical devices – Part 3: Tests for genotoxicity, carcinogenicity and reproductive toxicity*. 2014. <<https://www.iso.org/standard/55614.html>>.

4. "ISO 10993-5." *Biological evaluation of medical devices – Part 5: Tests for in vitro cytotoxicity*. 2009. <<https://www.iso.org/standard/36406.html>>.
5. "ISO 10993-6." *Biological evaluation of medical devices – Part 6: Tests for local effects after implantation*. 2016. <<https://www.iso.org/standard/61089.html>>.
6. "ISO 14242-1." *Implants for surgery – Wear of total hip-joint prostheses – Part 1: Loading and displacement parameters for wear-testing machines and corresponding environmental conditions for test*. 2014. <<https://www.iso.org/standard/63073.html>>.
7. "ISO 14704." *Fine ceramics (advanced ceramics, advanced technical ceramics) – Test method for flexural strength of monolithic ceramics at room temperature*. 2016. <<https://www.iso.org/standard/65411.html>>.
8. "ISO 14705." *Fine ceramics (advanced ceramics, advanced technical ceramics) – Test method for hardness of monolithic ceramics at room temperature*. 2016. <<https://www.iso.org/standard/65412.html>>.
9. "ISO 17561." *Fine ceramics (advanced ceramics, advanced technical ceramics) - Test method for elastic moduli of monolithic ceramics at room temperature by sonic resonance*. 2012. <<https://www.iso.org/standard/30748.html>>.
10. "ISO 21618." *Fine ceramics (advanced ceramics, advanced technical ceramics) – Test method for fracture resistance of monolithic ceramics at room temperature by indentation fracture (IF) method*. 2019. <<https://www.iso.org/standard/71248.html>>.
11. "ISO 22214." *Fine ceramics (advanced ceramics, advanced technical ceramics) – Test method for cyclic bending fatigue of monolithic ceramics at room temperature*. 2006. <<https://www.iso.org/standard/36167.html>>.
12. "ISO 5834-3." *Implants for surgery – Ultra-high-molecular-weight polyethylene – Part 3: Accelerated ageing methods*. 2019. <<https://www.iso.org/standard/73676.html>>.
13. "ISO 6474-2." *Implants for surgery – Ceramic materials – Part 2: Composite materials based on a high-purity alumina matrix with zirconia reinforcement*. 2019. <<https://www.iso.org/standard/72592.html>>.

References

1. Guojing Yang et al., Feasibility and Safety of 2-Day Discharge After Fast-Track Total Hip Arthroplasty: A Chinese Experience; *Journal of Arthroplasty*, Volume 31, Issue 8, August 2016, Pages 1686-1692.e1. <https://doi.org/10.1016/j.arth.2016.02.011>
2. Sagar Gaikwad et al., Evaluation of clinical outcome of cementless ceramic on ceramic primary total hip replacement in young patients of avascular necrosis of femoral head; *Journal of Arthroscopy and Joint Surgery*, Available online 3 December 2020. <https://doi.org/10.1016/j.jajs.2020.11.004>
3. Charnley J., Arthroplasty of the hip. A new operation; *Lancet* 1961: 1129–32. [https://doi.org/10.1016/s0140-6736\(61\)92063-3](https://doi.org/10.1016/s0140-6736(61)92063-3)
4. P. Boutin, Total arthroplasty of the hip by fritted alumina prosthesis. Experimental study and 1st clinical applications; *Orthopaedics & Traumatology: Surgery & Research*, Volume 100, Issue 1, February 2014, Pages 15-21. <https://doi.org/10.1016/j.rcot.2013.12.006>
5. <https://www.ceramtec-medical.com/en/biolox>
6. B. Sonny Bal et al., Ceramic Materials in Total Joint Arthroplasty; *Seminars in Arthroplasty*, Volume 17, Issues 3–4, Sep–Dec 2006, Pages 94-101. <https://doi.org/10.1053/j.sart.2006.09.002>
7. Christel P. et al., Biomechanical compatibility and design of ceramic implants for orthopedic surgery; *Annals of the New York Academy of Sciences*, 1988, 523:234-56. <https://doi.org/10.1111/j.1749-6632.1988.tb38516.x>
8. Massimiliano Merola, Saverio Affatato, Materials for Hip Prostheses: A Review of Wear and Loading Considerations; *Materials* 2019, 12(3), 495. <https://doi.org/10.3390/ma12030495>
9. <https://www.fda.gov/inspections-compliance-enforcement-and-criminal-investigations/enforcement-story-archive/center-devices-and-radiological-health-continued-2001>
10. Ian C. Clarke, Metastable Nature of Zirconia Femoral Heads From a 20-Year Perspective Of Clinical and Simulator Wear Studies; *Seminars in Arthroplasty*, Volume 17, Issues 3–4, September–December 2006, Pages 165-178. <https://doi.org/10.1053/j.sart.2006.09.012>
11. Ian C. Clarke et al., Current Status of Zirconia Used in Total Hip Implants; *J Bone Joint Surg Am*. 2003; 85-A Suppl 4:73-84. <https://doi.org/10.2106/00004623-200300004-00009>
12. Jérôme Chevalier, Leading Opinion: What future for zirconia as a biomaterial? *Biomaterials* Volume 27, Issue 4, February 2006, Pages 535-543. <https://doi.org/10.1016/j.biomaterials.2005.07.034>
13. B. Sonny Bal et al., Testing of silicon nitride ceramic bearings for total hip arthroplasty, *Journal of Biomedical Materials Research Part B Applied Biomaterials* 87(2):447-54, November 2008. <https://doi.org/10.1002/jbm.b.31123>
14. B. Sonny Bal et al., Fabrication and Testing of Silicon Nitride Bearings in Total Hip Arthroplasty: Winner of the 2007 "HAP" PAUL Award; *The Journal of Arthroplasty*, Volume 24, Issue 1, January 2009, Pages 110-116. <https://doi.org/10.1016/j.arth.2008.01.300>

15. Ian C. Clarke et al., Silicon nitride bearings: An alternative to oxide ceramics in total hip arthroplasty; Orthopaedic Proceedings Vol. 98-B, No. SUPP_1 2018
https://www.researchgate.net/publication/291189596_Silicon_nitride_bearings_an_alternative_to_oxide_ceramics_in_total_hip_arthroplasty
16. Makiko Yorifuji, Saverio Affatato et al., Wear Simulation of Ceramic-on-Crosslinked Polyethylene Hip Prostheses: A New Non-Oxide Silicon Nitride versus the Gold Standard Composite Oxide Ceramic Femoral Heads; Materials (Basel). 2020 Jun 29, 13(13):2917.
<https://doi.org/10.3390/ma13132917>
17. Mazen Al-Hajjar et al., Combined wear and ageing of ceramic-on-ceramic bearings in total hip replacement under edge loading conditions; Materials Volume 98, October 2019, Pages 40-47. <https://doi.org/10.1016/j.jmbbm.2019.05.011>
18. Giuseppe Pezzotti et al., On the molecular interaction between femoral heads and polyethylene liners in artificial hip joints: phenomenology and molecular scale phenomena; Biomed Mater. 2016 Dec 2;12(1):015005. <https://doi.org/10.1088/1748-605X/12/1/015005>
19. B.J. McEntire et al., Data-Driven Innovations in Joint Replacement: Do Ceramic Femoral Heads Contribute to Polyethylene Oxidation? J. Ceram. Sci. Tech., 08 [01] 1-6 (2017). <https://doi.org/10.4416/JCST2016-00100>
20. Giuseppe Pezzotti et al., Oxide ceramic femoral heads contribute to the oxidation of polyethylene liners in artificial hip joints; Journal of the Mechanical Behavior of Biomedical Materials 82 (2018) 168–182. <https://doi.org/10.1016/j.jmbbm.2018.03.021>
21. T. J. Webster et al., Anti-infective and osteointegration properties of silicon nitride, poly(ether ether ketone), and titanium implants; Acta Biomaterialia, Volume 8, Issue 12, December 2012, Pages 4447-4454. <https://doi.org/10.1016/j.actbio.2012.07.038>
22. Deborah J Gorth et al., Decreased bacteria activity on Si₃N₄ surfaces compared with PEEK or titanium; Int J Nanomedicine. 2012; 7:4829-40. <https://doi.org/10.2147/ijn.s35190>
23. Seniz R. Kushan Akin et al., A comparative study of silicon nitride and SiAlON ceramics against E. coli; Ceramics International, Volume 47, Issue 2, 15 January 2021, Pages 1837-1843. <https://doi.org/10.1016/j.ceramint.2020.09.012>

Figures

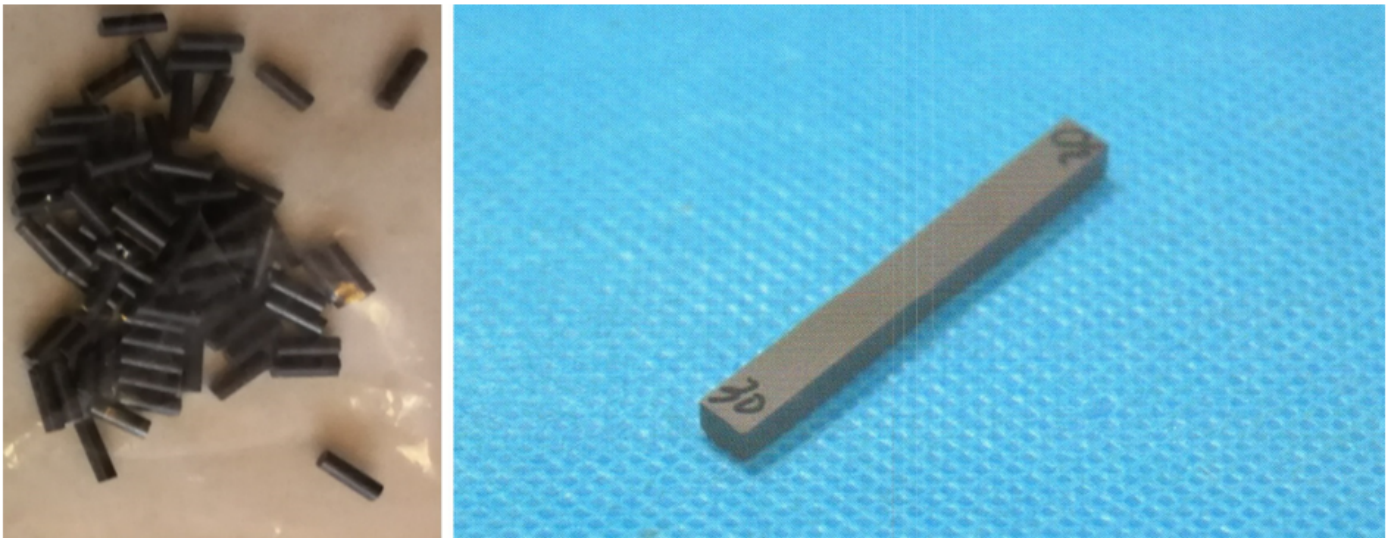

Figure 1

sample bars ($\Phi 2*6$ mm & $3*4*50$ mm)

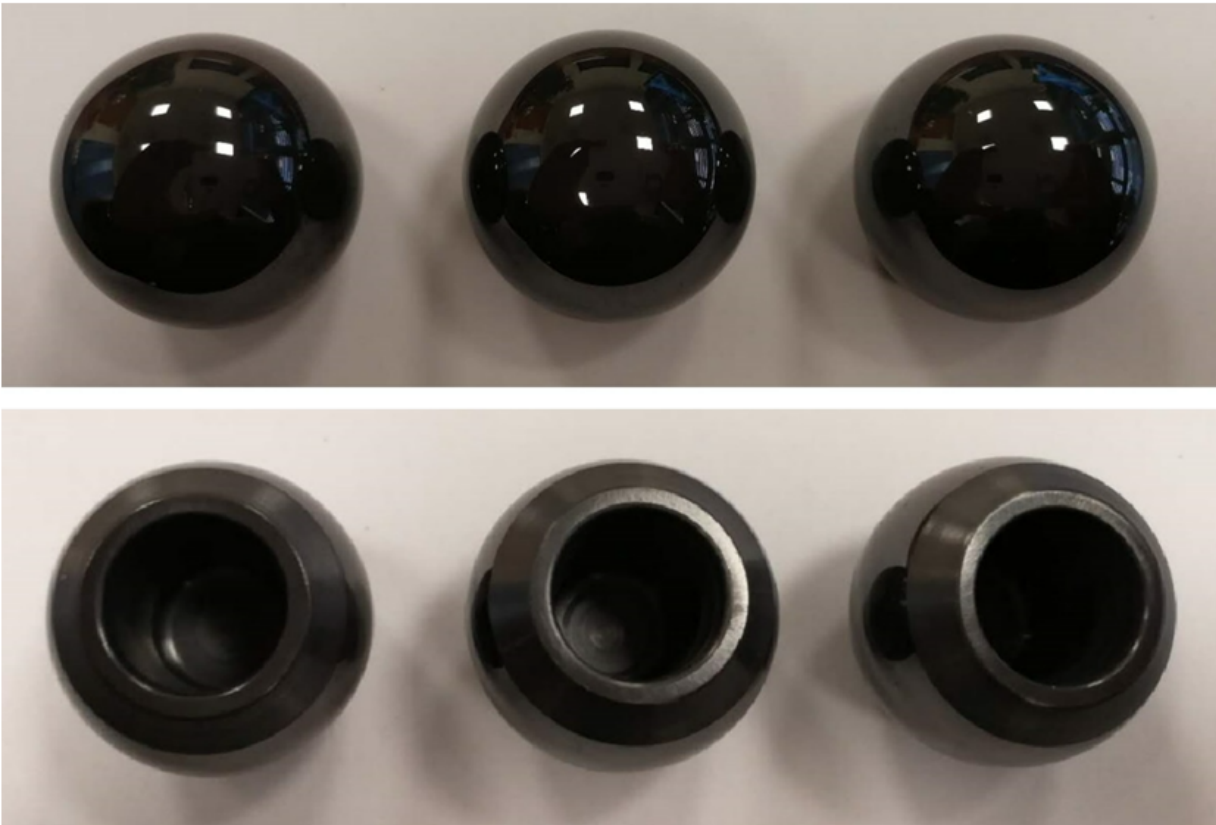

Figure 2
femoral heads ($\Phi 28$ mm)

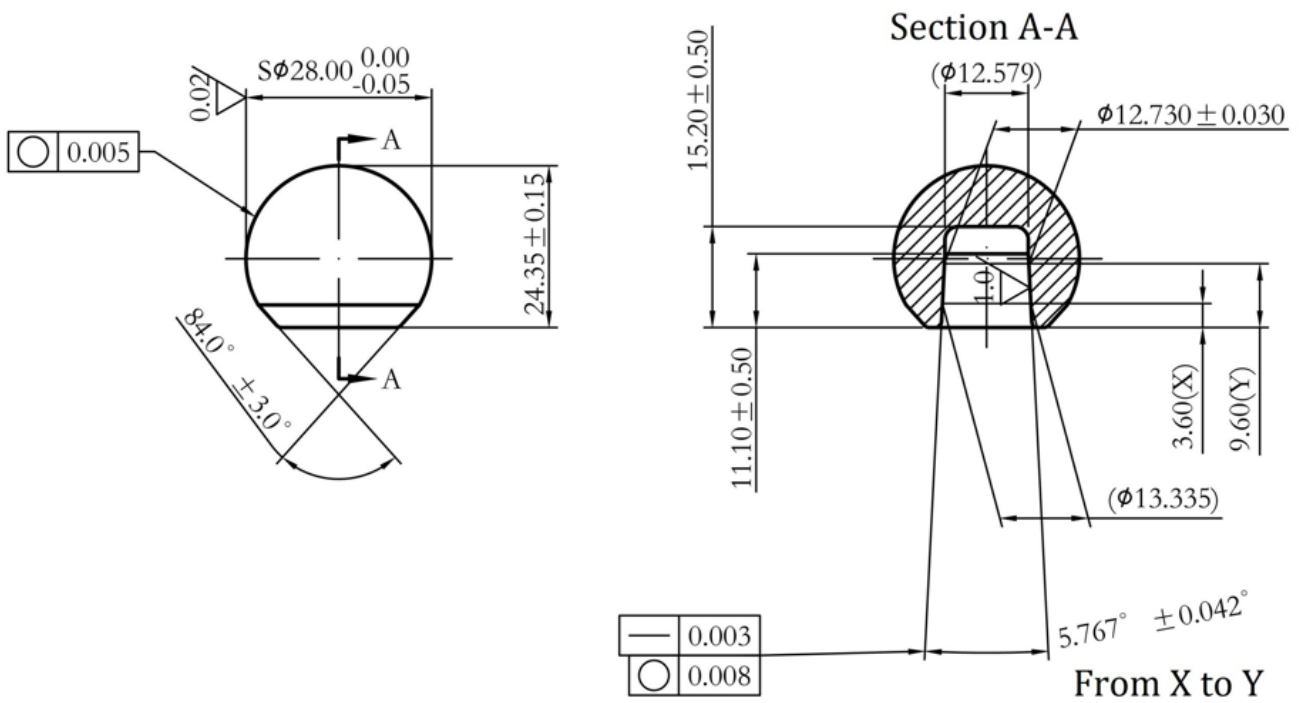

Figure 3
dimension & tolerance of femoral head ($\Phi 28$ mm - Type L)



Figure 4

customized total hip system for pig



Figure 5

Bama minipig involved in the experiment



Figure 6

Total hip implantation in pig From left to right: Lateral position, disinfection & draping – hip joint exposure – acetabular preparation – prosthesis implantation



Figure 7

Postoperative posture



Figure 8

CT scan result (Test group, No. 4 pig)

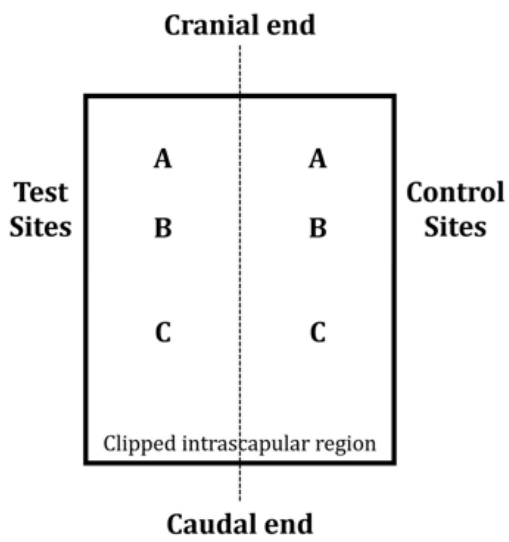

Figure 9

location of intradermal injection sites

Supplementary Files

This is a list of supplementary files associated with this preprint. Click to download.

- [Appendix.docx](#)